

1776 – 2026

United
States
of
America



To Promote the Progress



of Science and Useful Arts

The Director

of the United States Patent and Trademark Office has received an application for a patent for a new and useful invention. The title and description of the invention are enclosed. The requirements of law have been complied with, and it has been determined that a patent on the invention shall be granted under the law.

Therefore, this United States

Patent

grants to the person(s) having title to this patent the right to exclude others from making, using, offering for sale, or selling the invention throughout the United States of America or importing the invention into the United States of America, and if the invention is a process, of the right to exclude others from using, offering for sale or selling throughout the United States of America, products made by that process, for the term set forth in 35 U.S.C. 154(a)(2) or (c)(1), subject to the payment of maintenance fees as provided by 35 U.S.C. 41(b). See the Maintenance Fee Notice on the inside of the cover.



**UNITED STATES
PATENT AND
TRADEMARK OFFICE**

Celebrating 250 years of life, liberty,
and the pursuit of innovation



DIRECTOR OF THE UNITED STATES PATENT AND TRADEMARK OFFICE

Maintenance Fee Notice

If the application for this patent was filed on or after December 12, 1980, maintenance fees are due three years and six months, seven years and six months, and eleven years and six months after the date of this grant, or within a grace period of six months thereafter upon payment of a surcharge as provided by law. The amount, number and timing of the maintenance fees required may be changed by law or regulation. Unless payment of the applicable maintenance fee is received in the United States Patent and Trademark Office on or before the date the fee is due or within a grace period of six months thereafter, the patent will expire as of the end of such grace period.

Patent Term Notice

If the application for this patent was filed on or after June 8, 1995, the term of this patent begins on the date on which this patent issues and ends twenty years from the filing date of the application or, if the application contains a specific reference to an earlier filed application or applications under 35 U.S.C. 120, 121, 365(c), or 386(c), twenty years from the filing date of the earliest such application (“the twenty-year term”), subject to the payment of maintenance fees as provided by 35 U.S.C. 41(b), and any extension as provided by 35 U.S.C. 154(b) or 156 or any disclaimer under 35 U.S.C. 253.

If this application was filed prior to June 8, 1995, the term of this patent begins on the date on which this patent issues and ends on the later of seventeen years from the date of the grant of this patent or the twenty-year term set forth above for patents resulting from applications filed on or after June 8, 1995, subject to the payment of maintenance fees as provided by 35 U.S.C. 41(b) and any extension as provided by 35 U.S.C. 156 or any disclaimer under 35 U.S.C. 253.



US012600553B1

(12) **United States Patent**
Hoffman et al.

(10) **Patent No.:** **US 12,600,553 B1**
(45) **Date of Patent:** **Apr. 14, 2026**

(54) **TOOLLESS CRATE ASSEMBLY WITH INTERCHANGEABLE CARTRIDGE**

USPC 206/305, 320, 521, 523
See application file for complete search history.

(71) Applicant: **Larson Packaging Company, LLC,**
Milpitas, CA (US)

(56) **References Cited**

(72) Inventors: **Mark A. Hoffman,** Park City, UT (US);
Hector Rafael Monrroy Gonzalez,
Fremont, CA (US); **David Matthew Skurla,**
San Jose, CA (US)

U.S. PATENT DOCUMENTS

(73) Assignee: **LARSON PACKAGING COMPANY, LLC,**
Milpitas, CA (US)

2,771,987 A *	11/1956	Kennedy	B65D 19/44 206/521
9,635,778 B2 *	4/2017	Tsai	H05K 7/1488
9,676,517 B2 *	6/2017	Jiang	B65D 19/42
10,850,757 B1 *	12/2020	Curlee	B62B 3/003
11,124,358 B2 *	9/2021	Wu	B65D 88/542
11,167,908 B2 *	11/2021	Moshe	B65D 19/44
11,276,435 B2 *	3/2022	Chen	B65D 81/057
11,388,836 B2 *	7/2022	Curlee	H05K 7/1495

(*) Notice: Subject to any disclaimer, the term of this patent is extended or adjusted under 35 U.S.C. 154(b) by 0 days.

* cited by examiner

(21) Appl. No.: **19/031,975**

Primary Examiner — Bryon P Gehman

(22) Filed: **Jan. 18, 2025**

(74) *Attorney, Agent, or Firm* — Adibi IP Group, PC;
Amir V. Adibi; Andrew C. Palmer

(51) **Int. Cl.**

(57) **ABSTRACT**

B65D 81/05	(2006.01)
B65D 81/107	(2006.01)
B65D 85/30	(2006.01)
B65D 85/64	(2006.01)
B65D 85/68	(2006.01)
B65D 88/12	(2006.01)
B65D 88/54	(2006.01)

A crate assembly includes a crate having a base and an interchangeable cartridge supported by the base. The interchangeable cartridge is insertable and removable from the base of the crate. The interchangeable cartridge includes a cartridge base and a well. The well is formed by a floater base, side rails, a back board, and a front board. Energy damping components are selected to support a desired load and are disposed between the cartridge base and the floater base thereby providing cushioning to a load carried in the crate. Brace brackets attach to ends of the side rails. After loading a server rack, openings on the front board slide over end bolts of the brace brackets thereby providing toolless securement of the load within the well. Worn cartridges are replaced with new cartridges thereby extending crate life and cartridges are customizable depending on application to support different load dimensions or weights.

(52) **U.S. Cl.**

CPC **B65D 81/058** (2013.01); **B65D 81/107** (2013.01); **B65D 85/30** (2013.01); **B65D 85/64** (2013.01); **B65D 85/68** (2013.01); **B65D 88/127** (2013.01); **B65D 88/542** (2013.01); **B65D 2585/649** (2013.01)

(58) **Field of Classification Search**

CPC B65D 81/05; B65D 81/058; B65D 81/107; B65D 85/30; B65D 85/64; B65D 85/68; B65D 88/127; B65D 88/542; B65D 2585/649

16 Claims, 28 Drawing Sheets

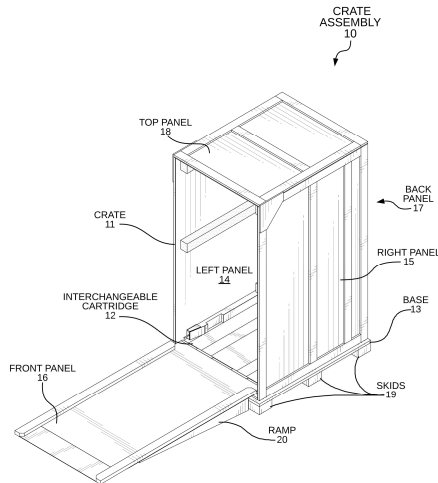

PERSPECTIVE VIEW OF SERVER RACK CRATE

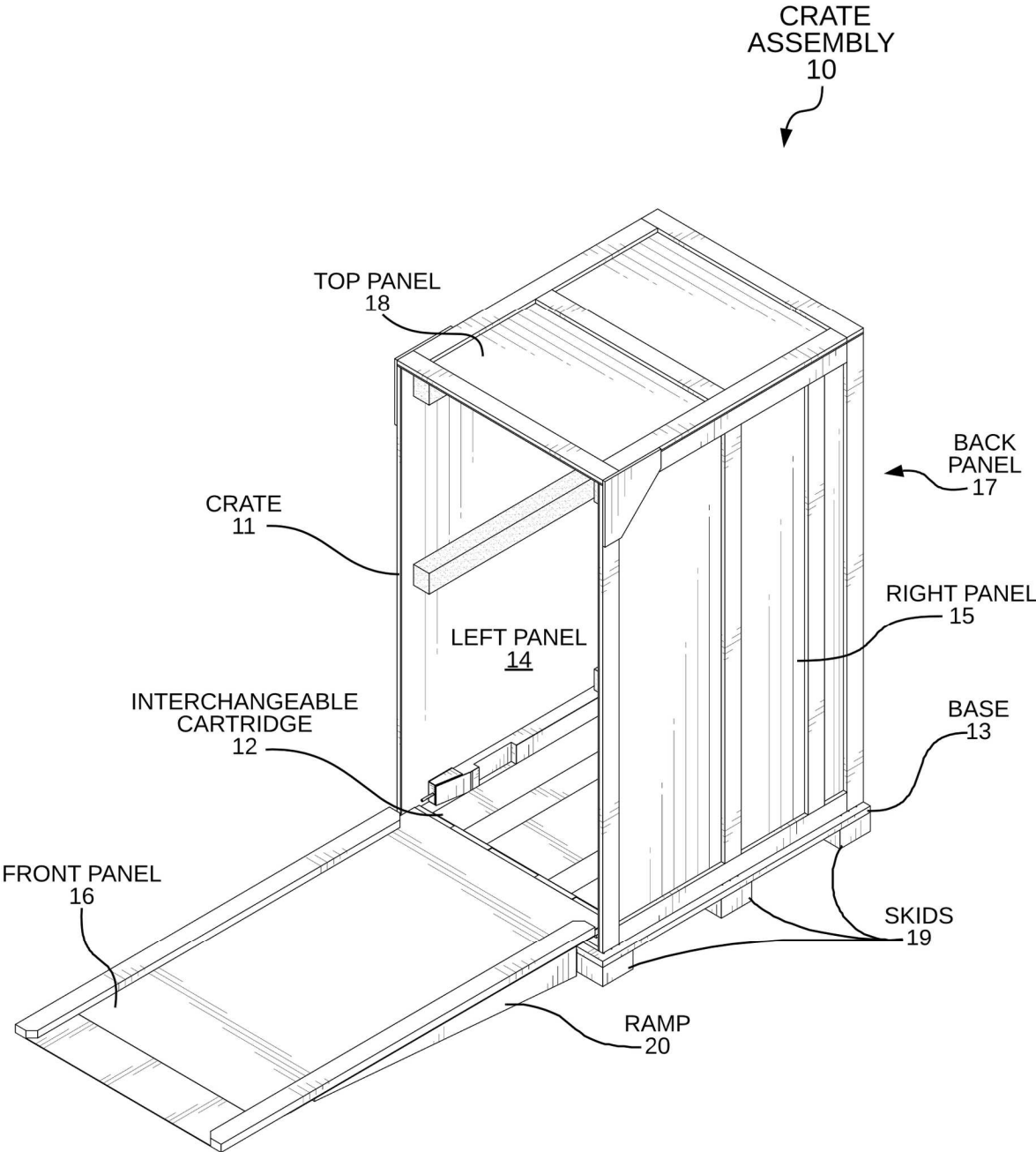

PERSPECTIVE VIEW OF SERVER RACK CRATE
FIG. 1

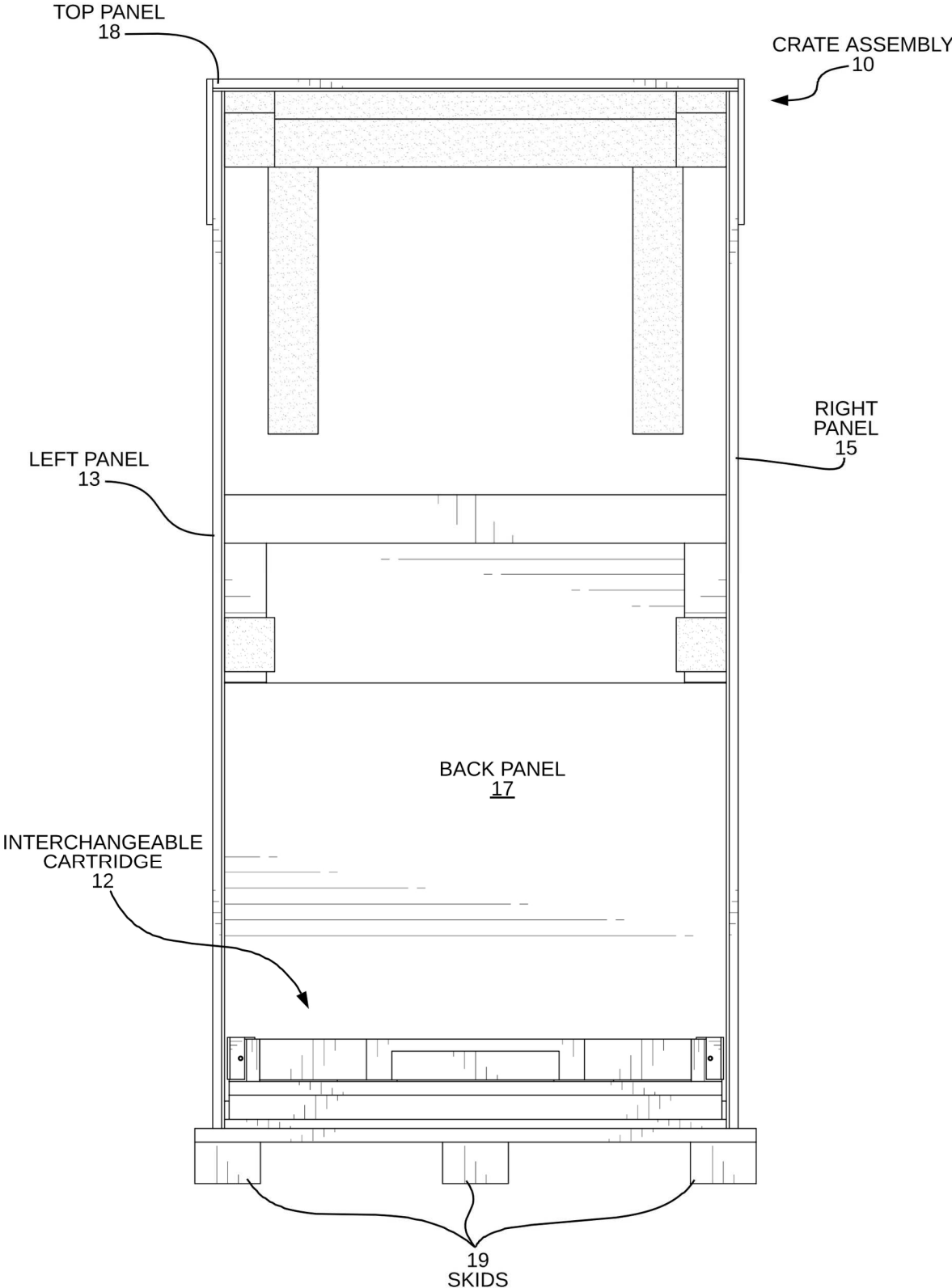

FRONT VIEW OF SERVER RACK CRATE
FIG. 2

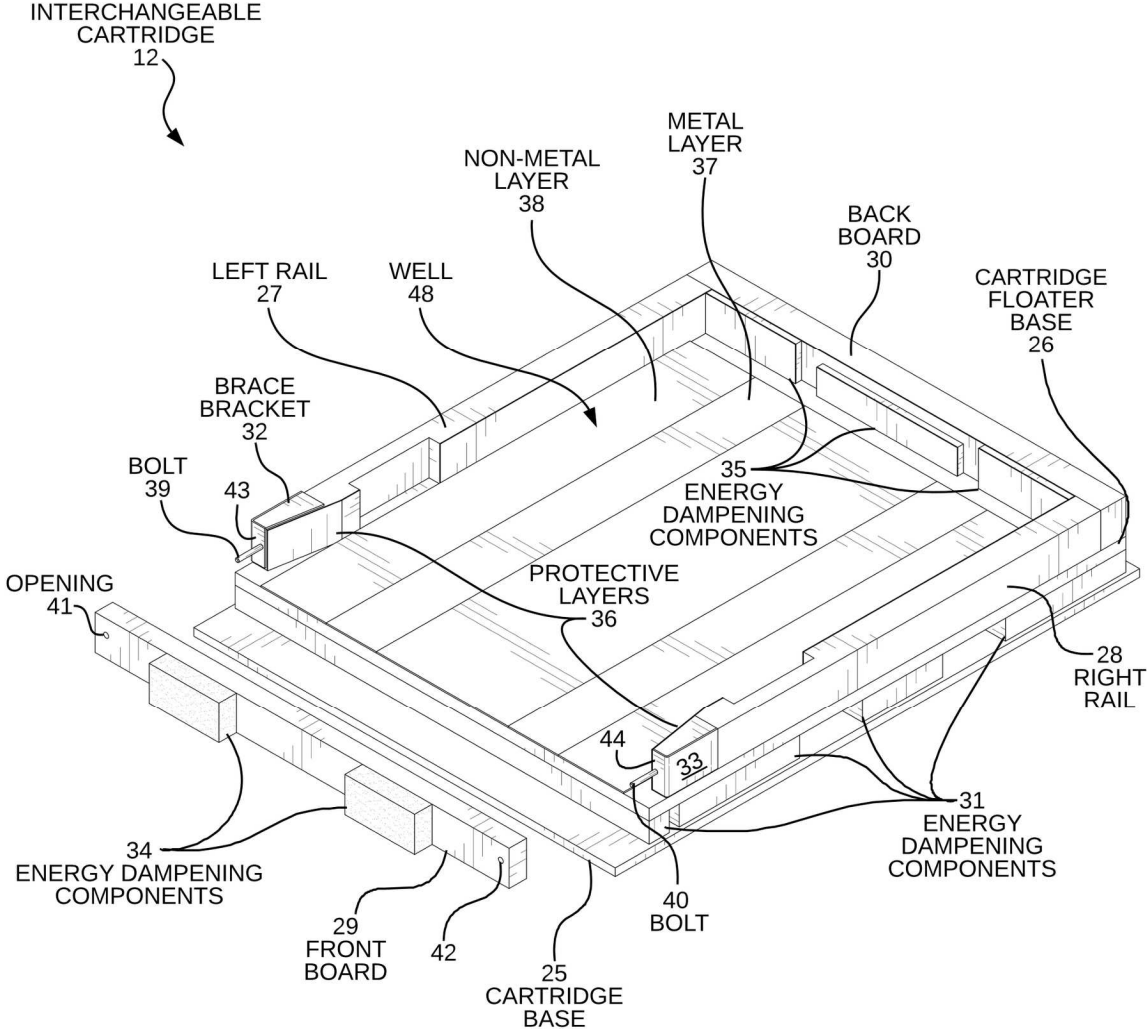

PERSPECTIVE VIEW OF INTERCHANGEABLE CARTRIDGE
FIG. 3

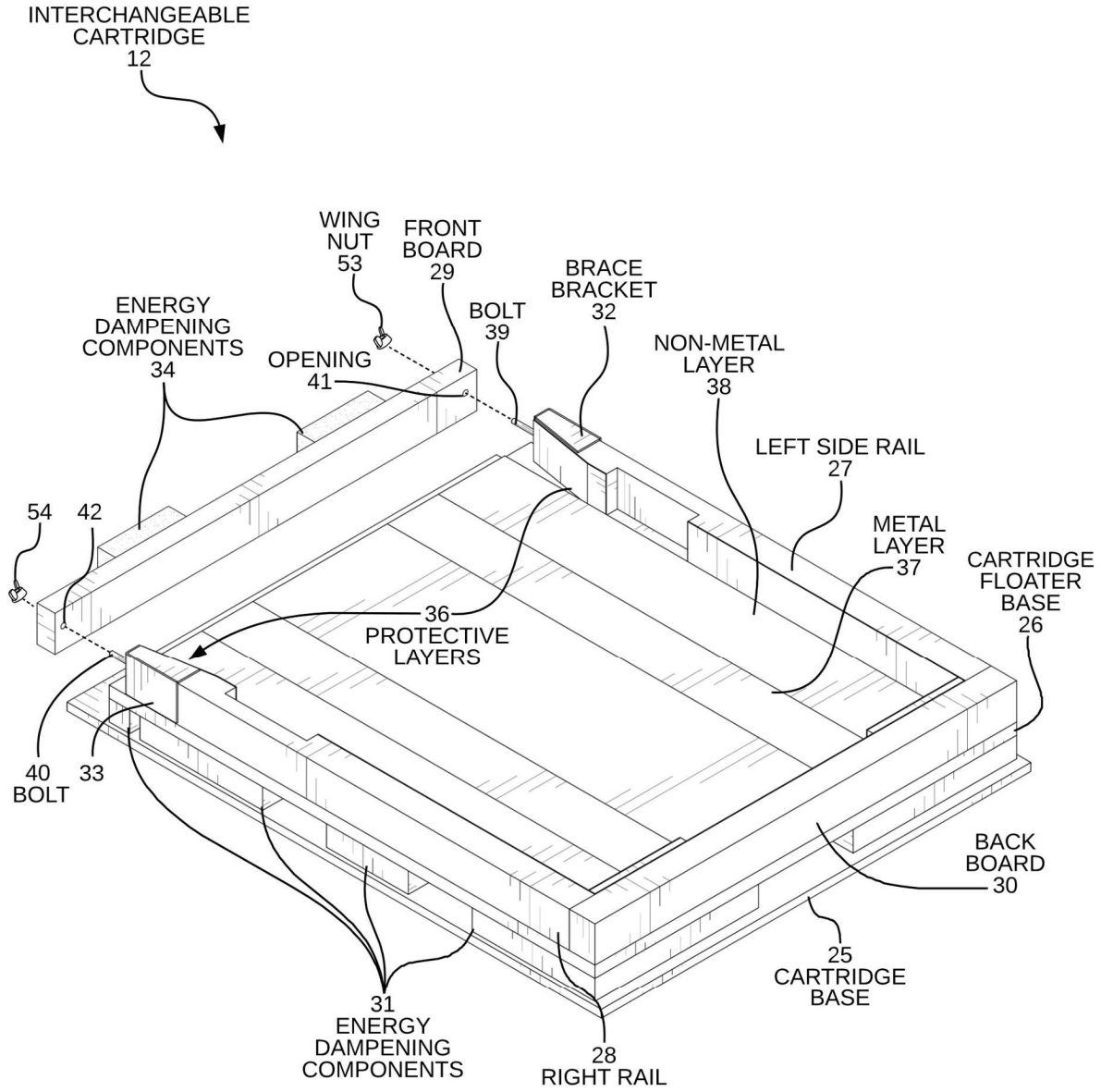

ANOTHER PERSPECTIVE VIEW OF INTERCHANGEABLE CARTRIDGE
FIG. 4

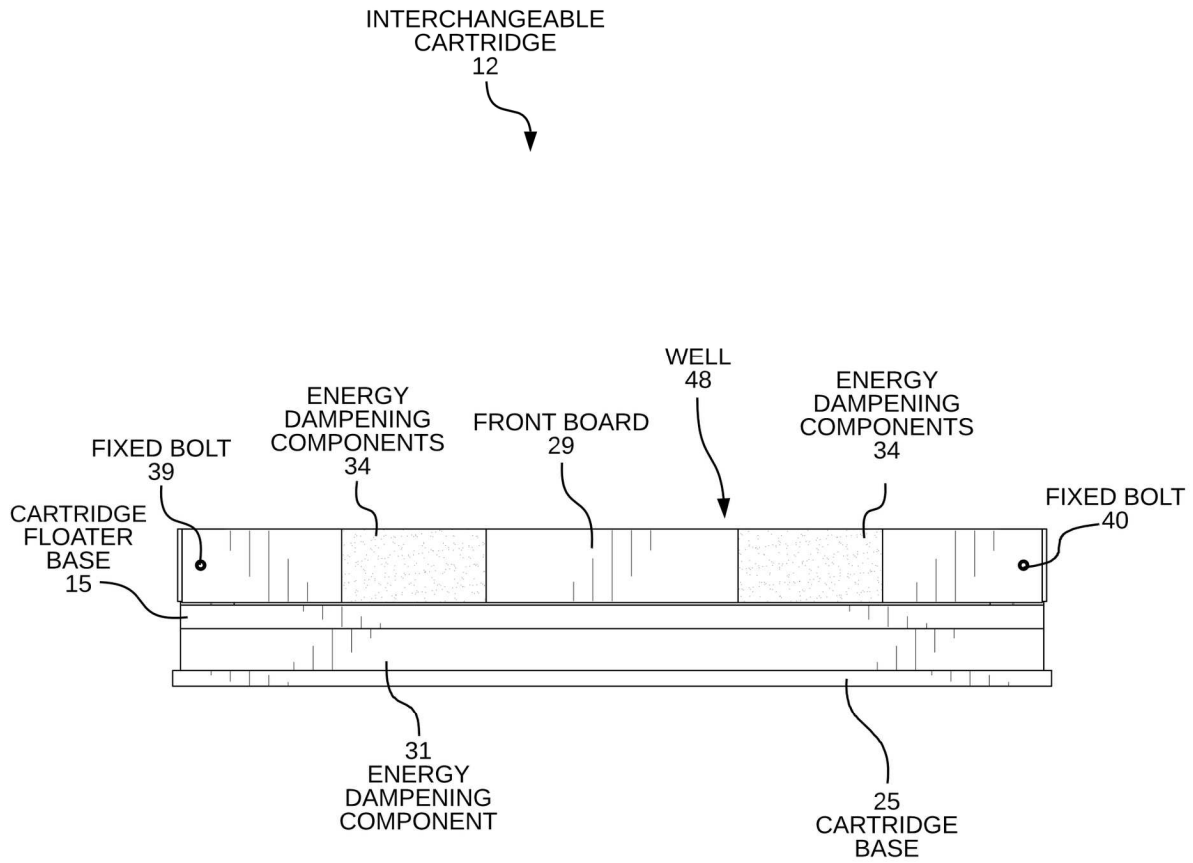

FRONT VIEW OF INTERCHANGEABLE CARTRIDGE
FIG. 5

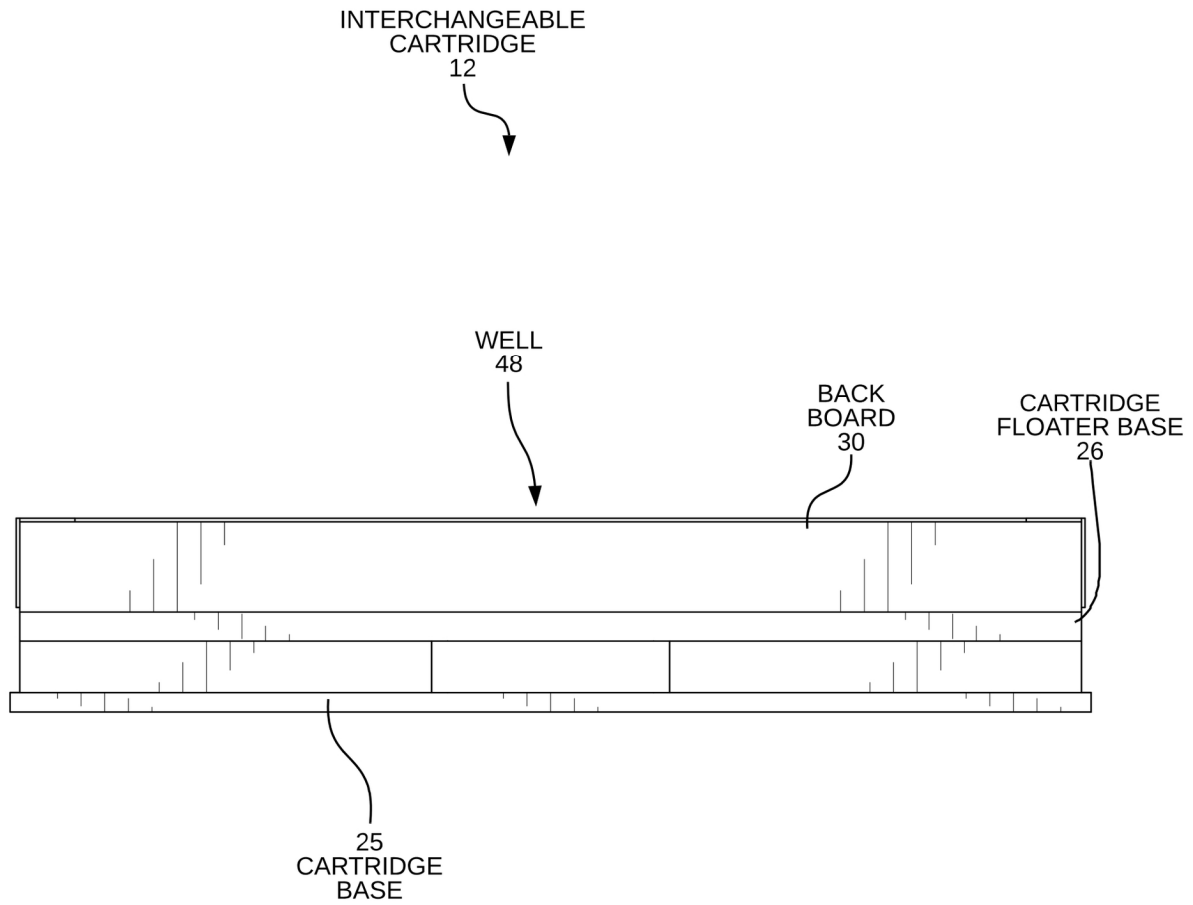

REAR VIEW OF INTERCHANGEABLE CARTRIDGE
FIG. 6

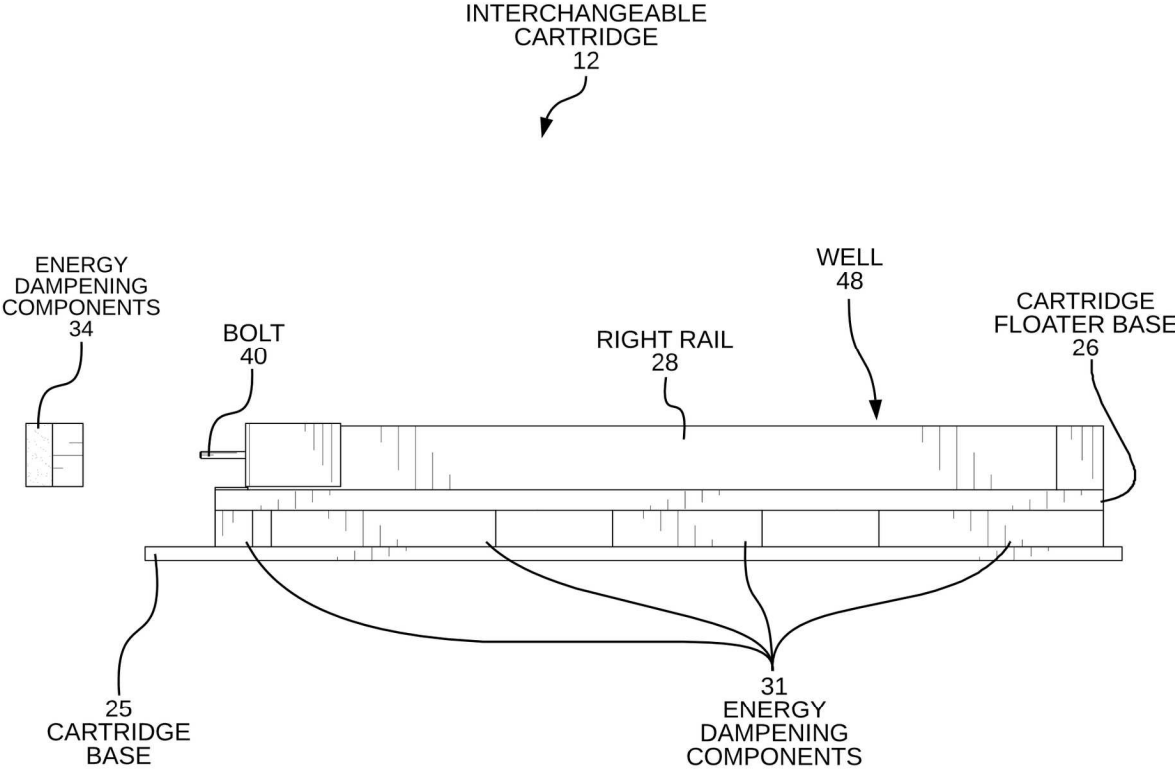

SIDE VIEW OF INTERCHANGEABLE CARTRIDGE
FIG. 7

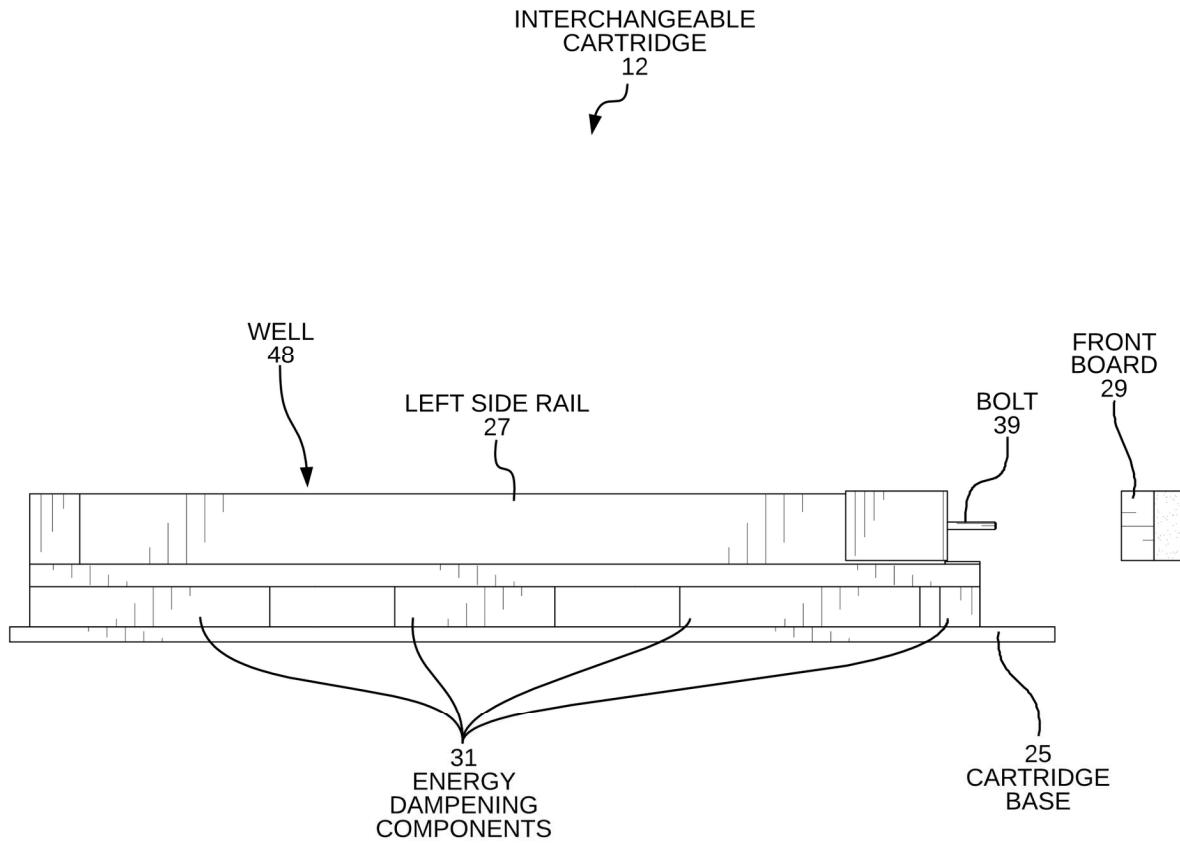

ANOTHER SIDE VIEW OF INTERCHANGEABLE
CARTRIDGE
FIG. 8

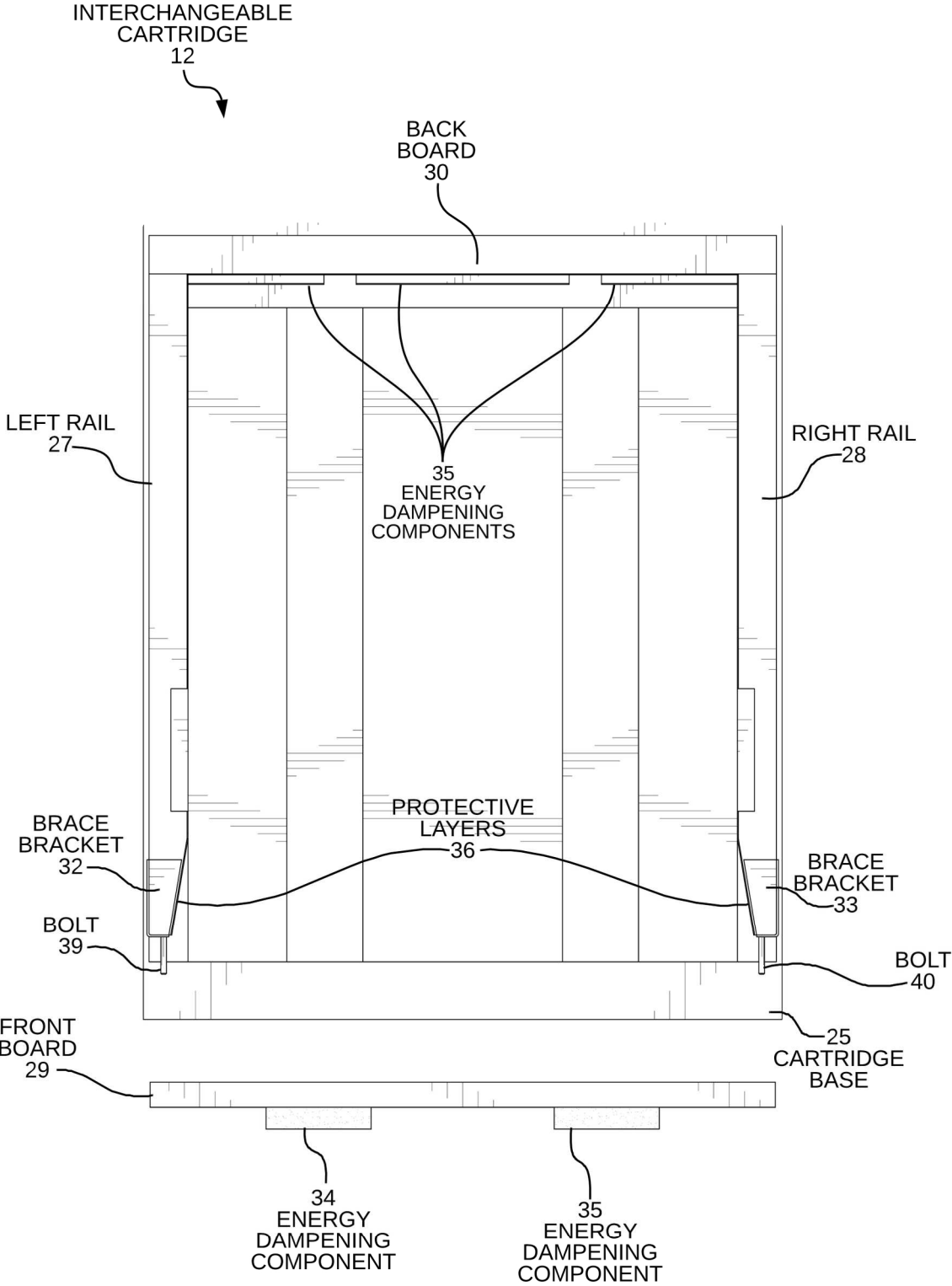

TOP VIEW OF INTERCHANGEABLE CARTRIDGE
FIG. 9

INTERCHANGEABLE
CARTRIDGE

12

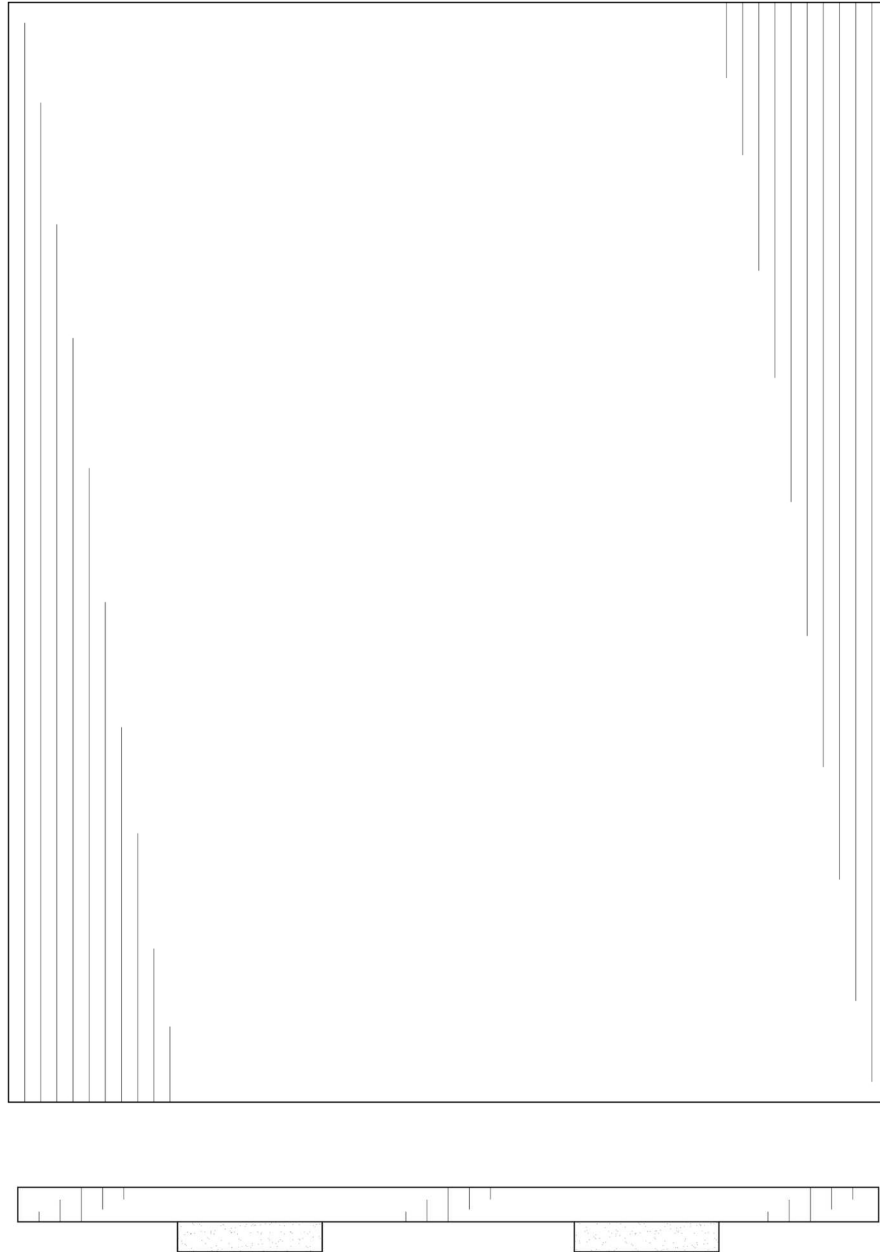

BOTTOM VIEW OF INTERCHANGEABLE CARTRIDGE
FIG. 10

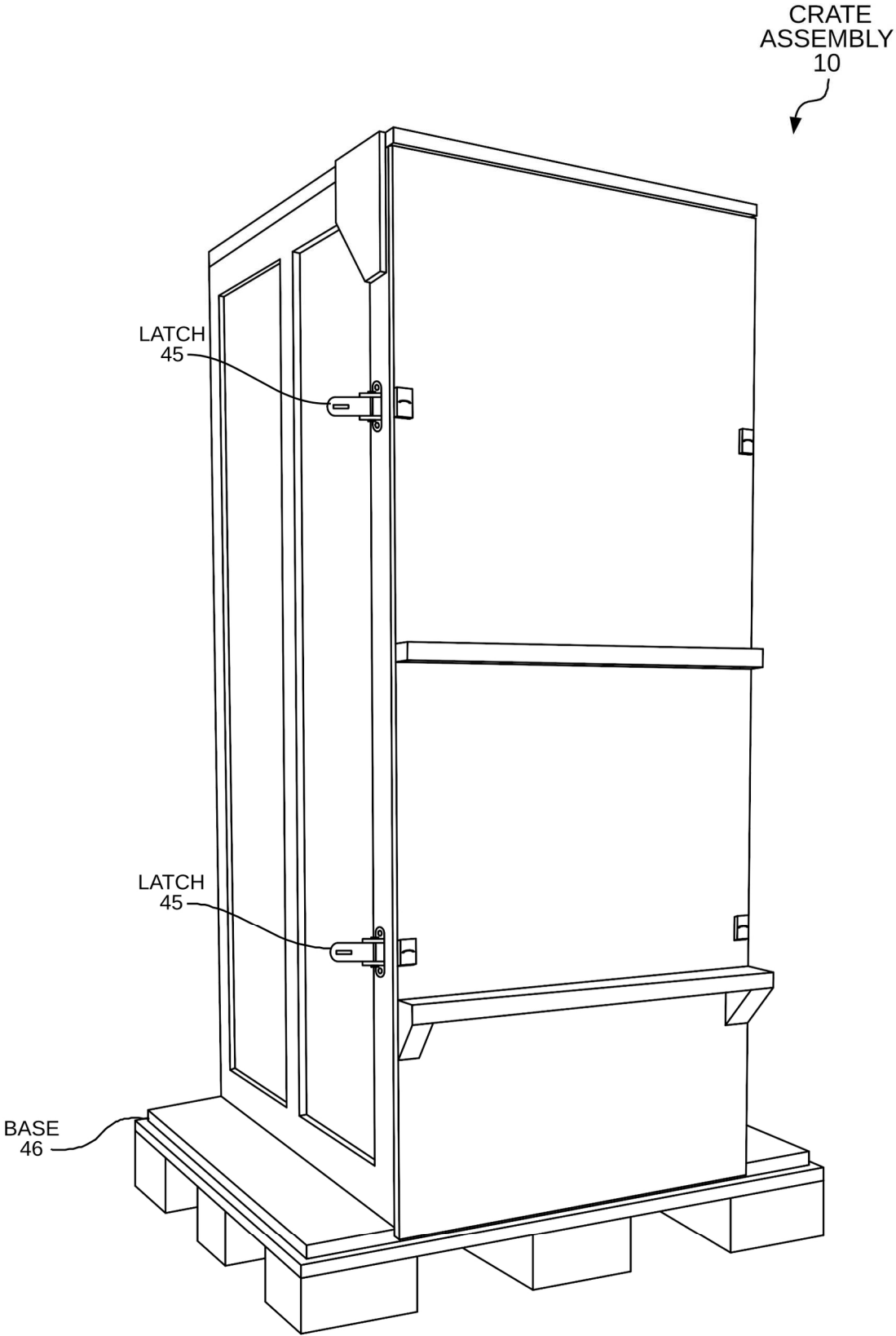

PERSPECTIVE VIEW OF CRATE ASSEMBLY
FIG. 11

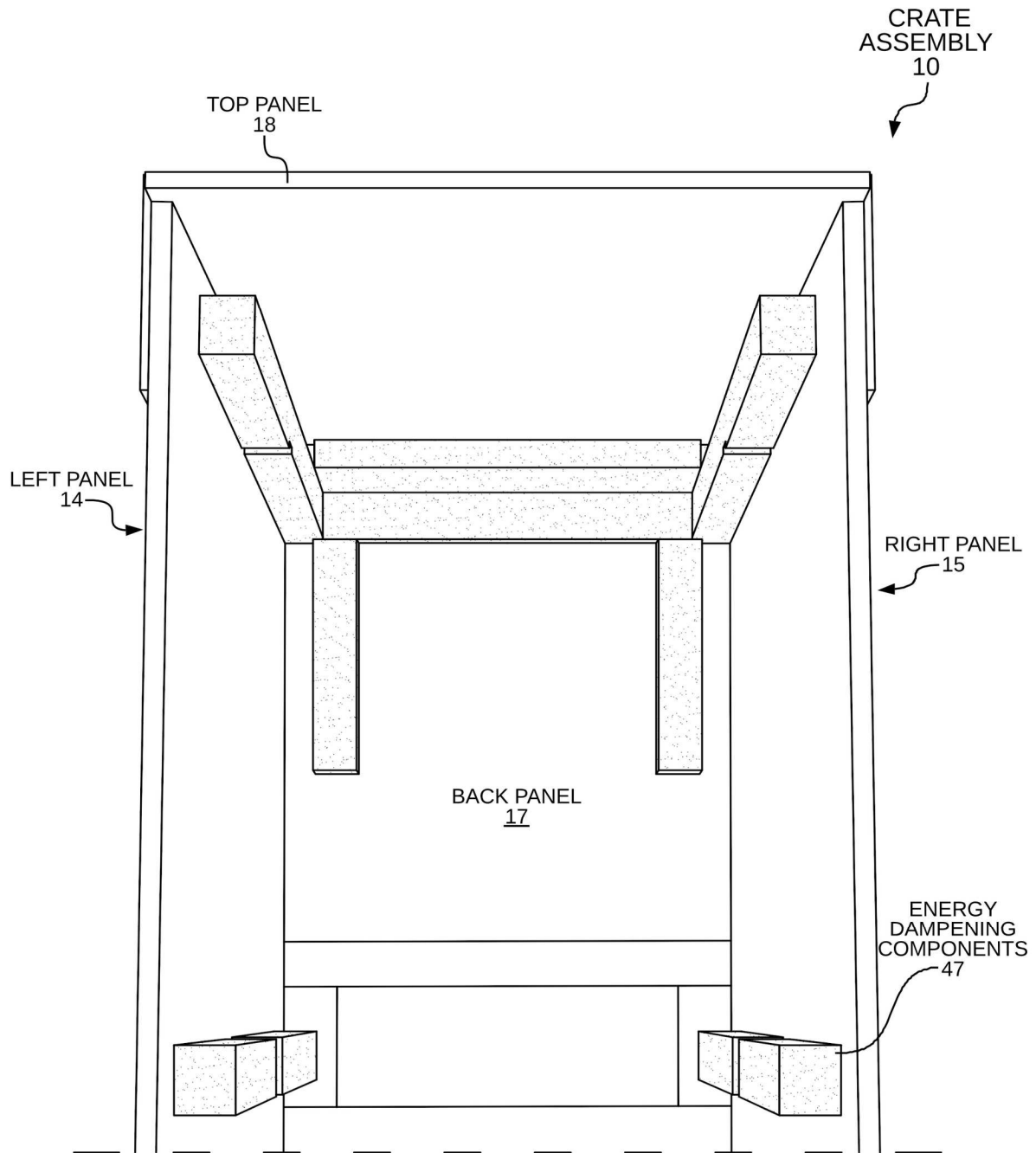

INTERIOR OF CRATE WITH ENERGY DAMPENING COMPONENTS
FIG. 12

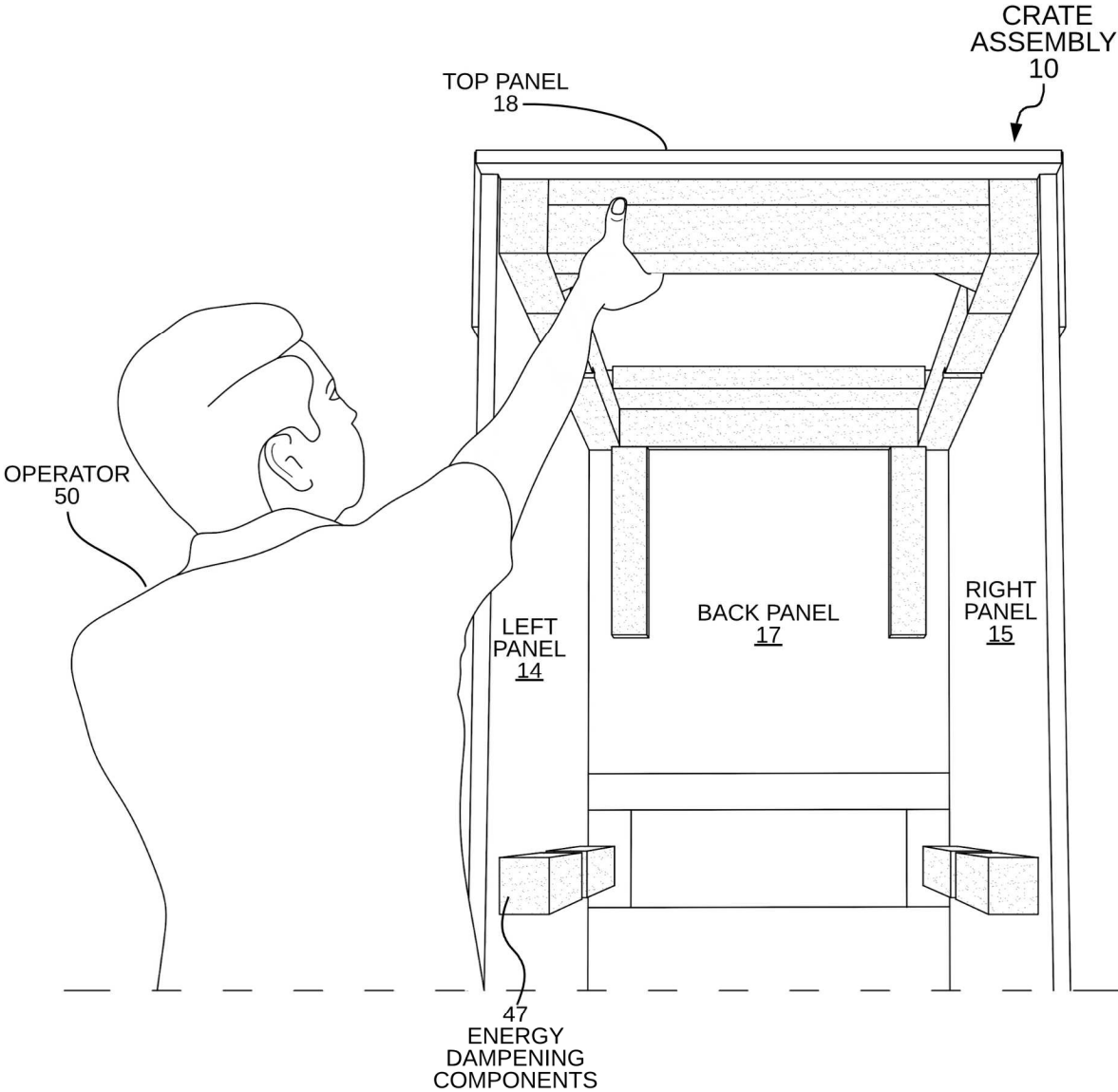

SECURING ENERGY DAMPENING COMPONENTS TO
CRATE INTERIOR
FIG. 13

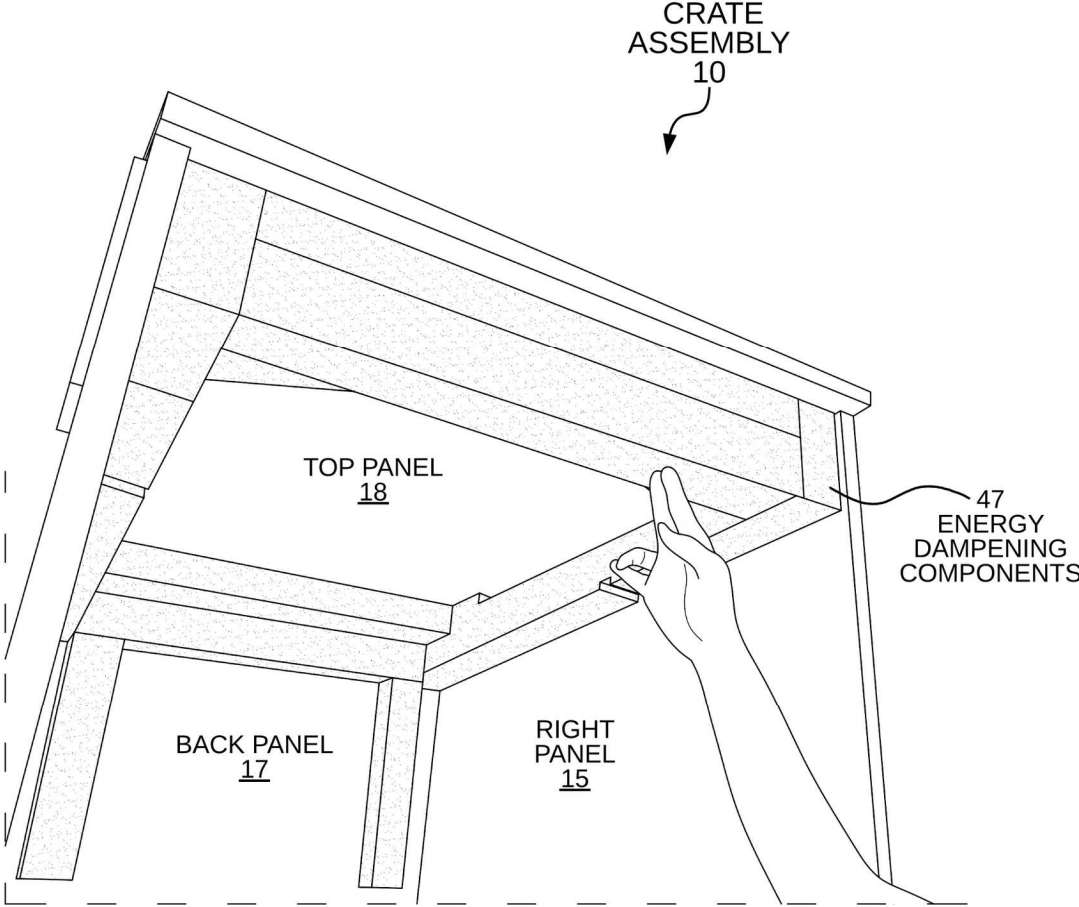

SECURING ENERGY DAMPENING COMPONENTS TO
CRATE INTERIOR
FIG. 14

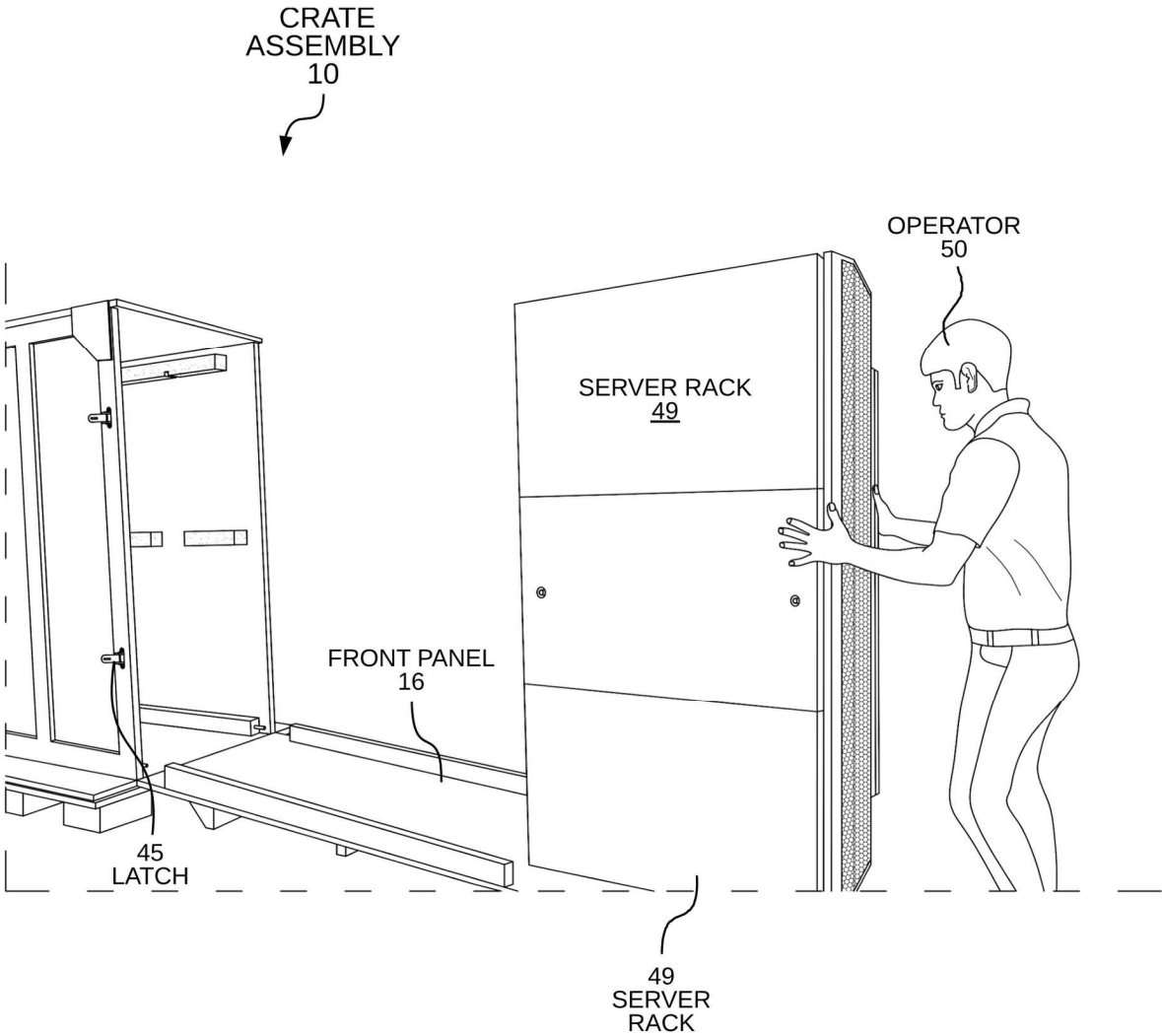

LOADING SERVER RACK ONTO CARTRIDGE
FIG. 15

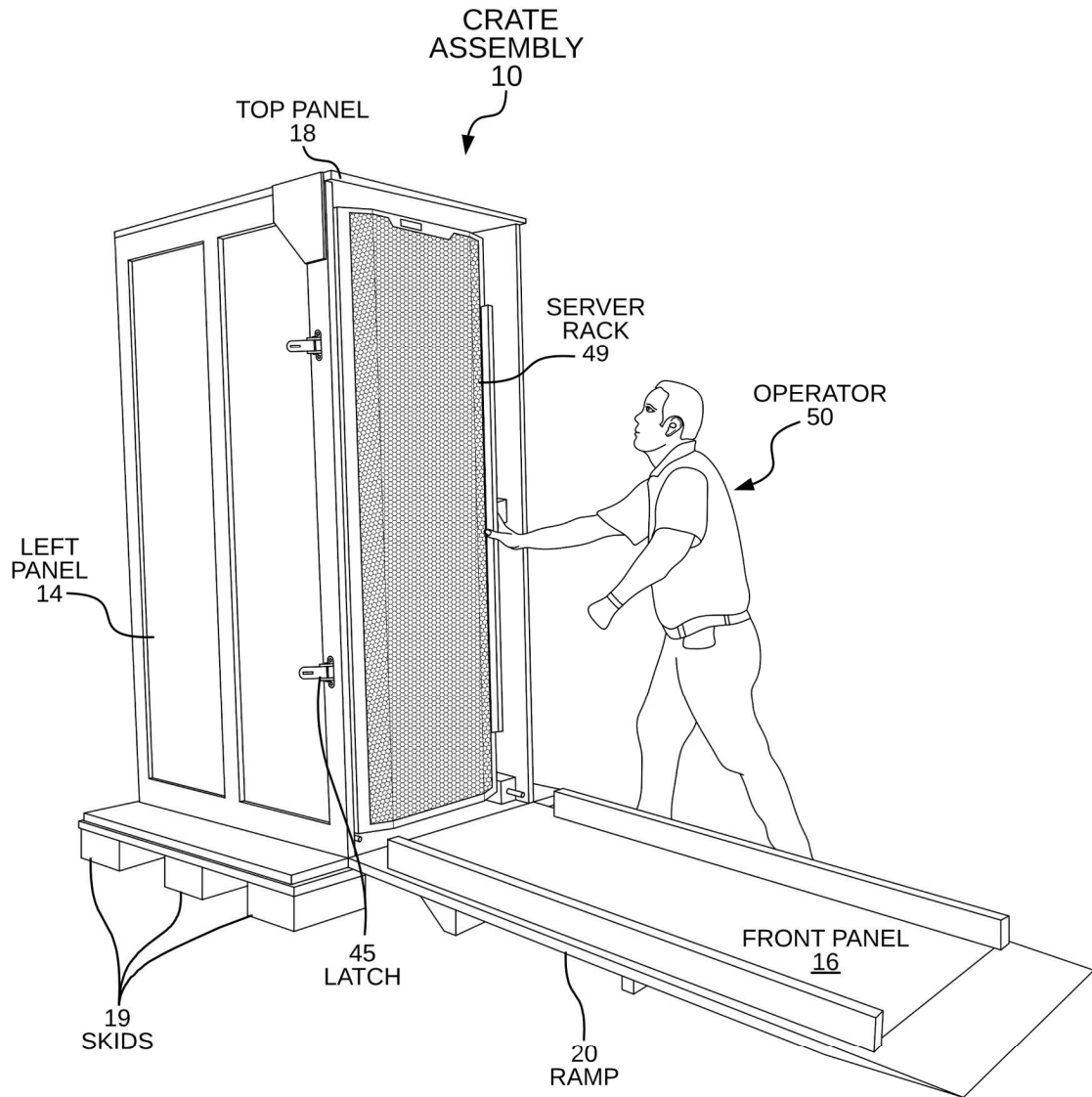

SERVER RACK LOADED ON CARTRIDGE
(BEFORE SECURING FRONT BOARD)
FIG. 16

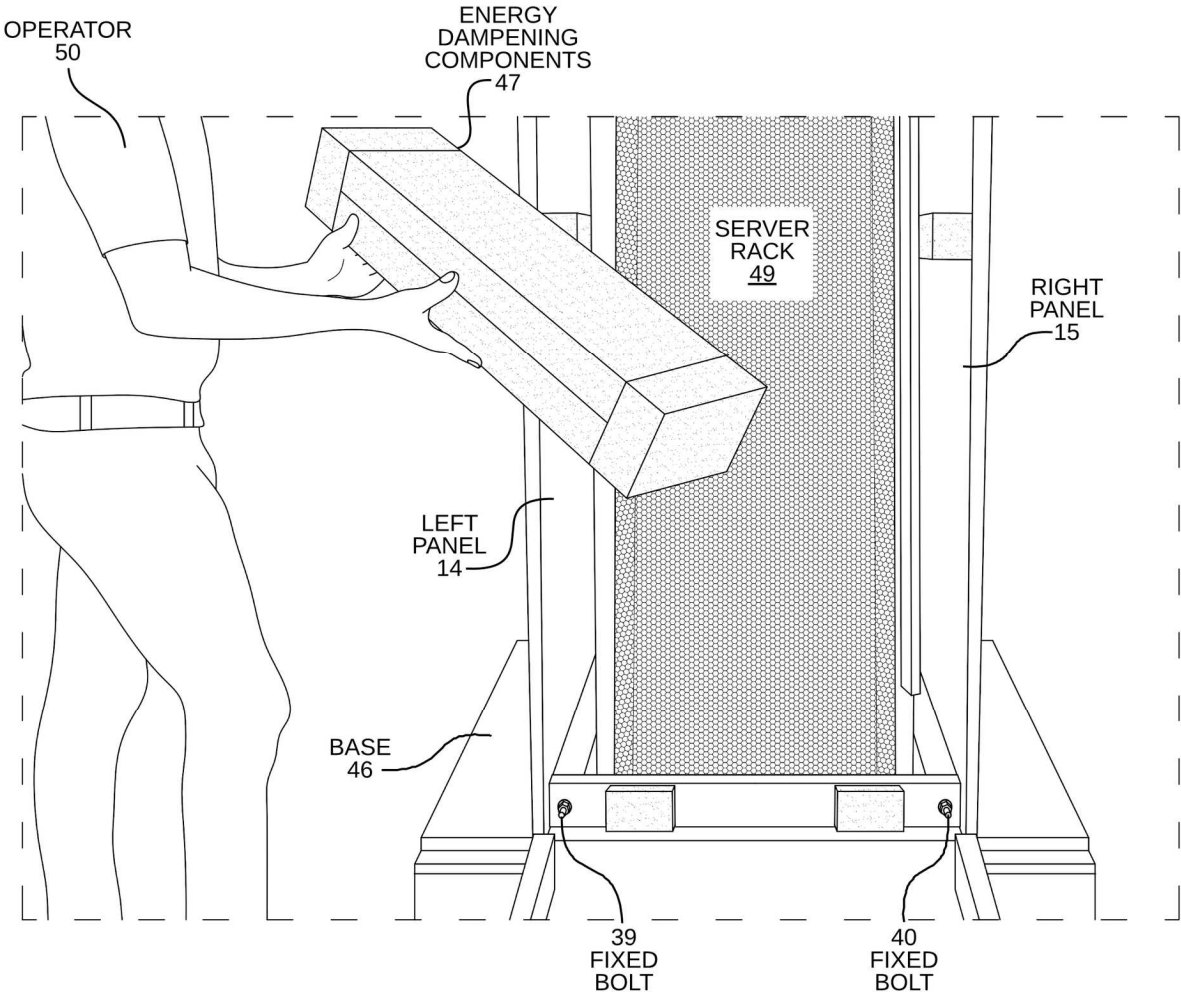

SECURING ENERGY DAMPENING COMPONENTS TO
CRATE INTERIOR
(AFTER SECURING FRONT BOARD)
FIG. 17

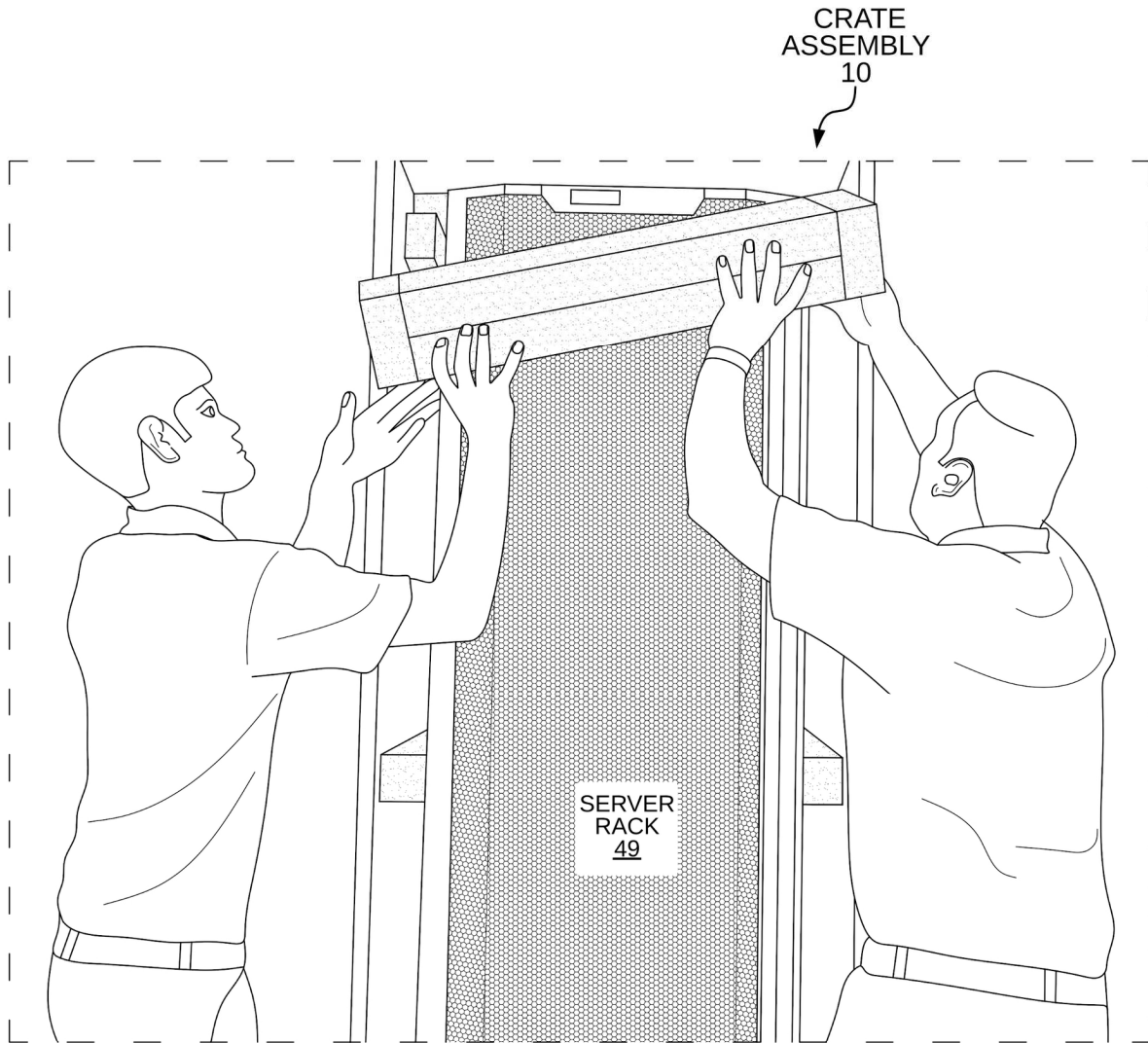

SECURING ENERGY DAMPENING COMPONENTS TO
CRATE INTERIOR
FIG. 18

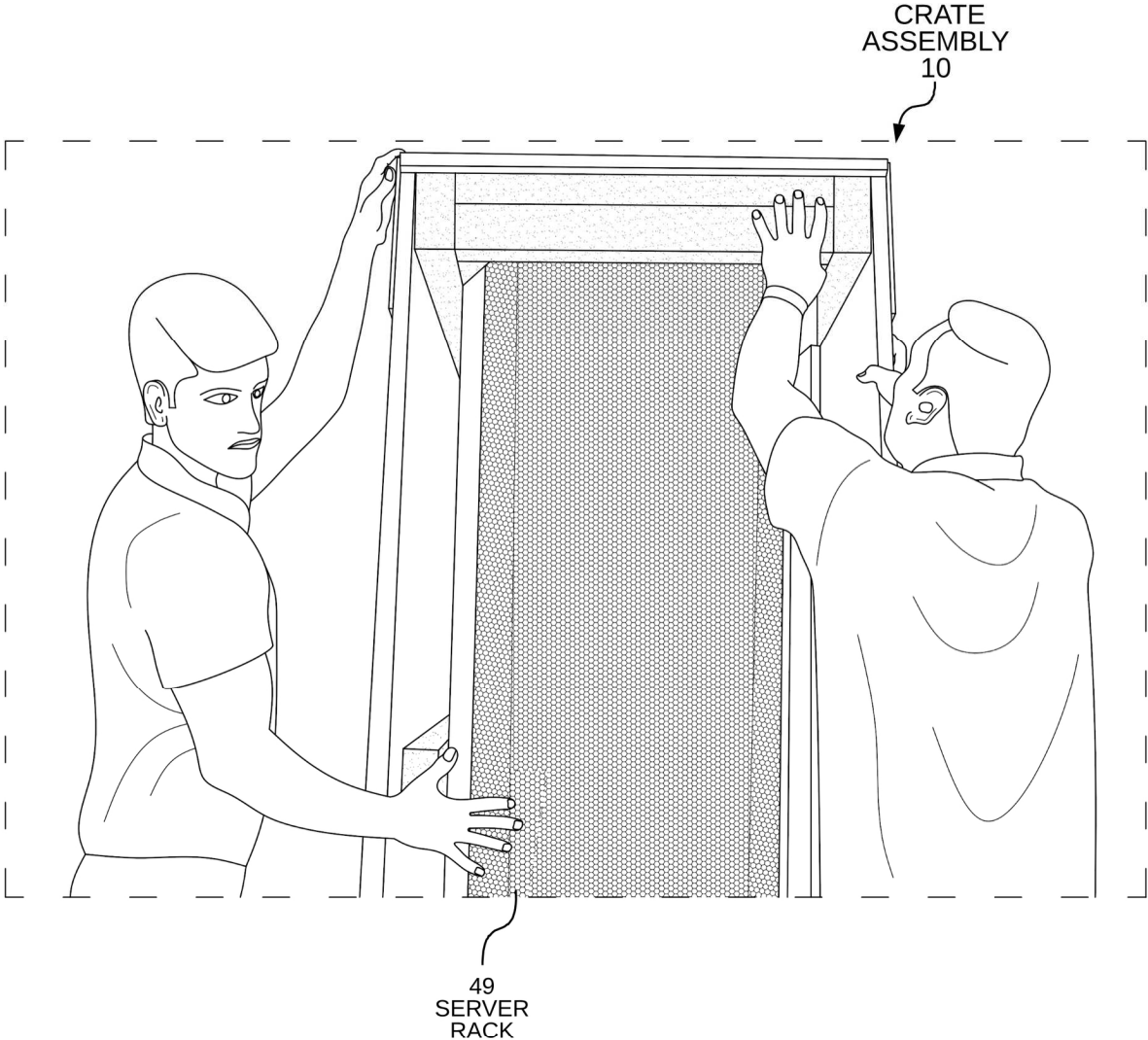

SECURING ENERGY DAMPENING COMPONENTS
TO CRATE INTERIOR
FIG. 19

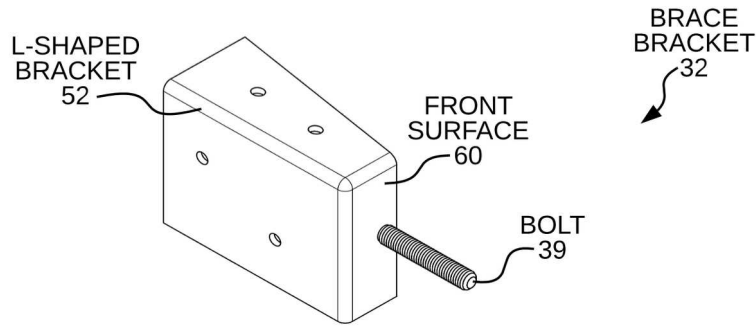

PERSPECTIVE VIEW OF BRACE BRACKET
FIG. 20A

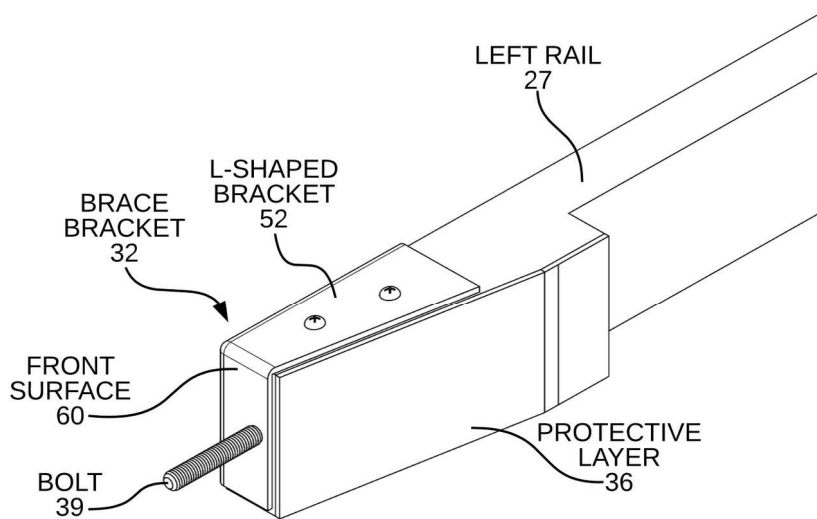

BRACE BRACKET ATTACHED TO SIDE RAIL
FIG. 20B

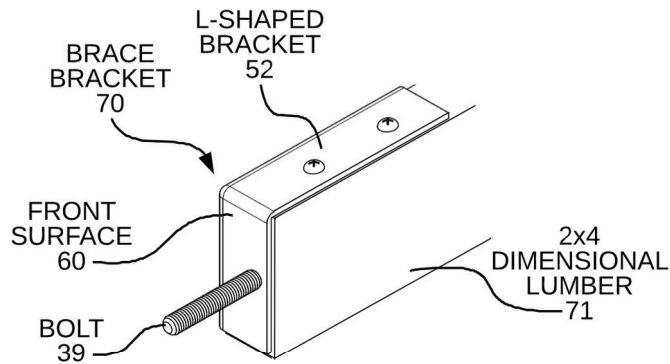

BRACE BRACKET ATTACHED TO DIMENSIONAL
LUMBER
FIG. 20C

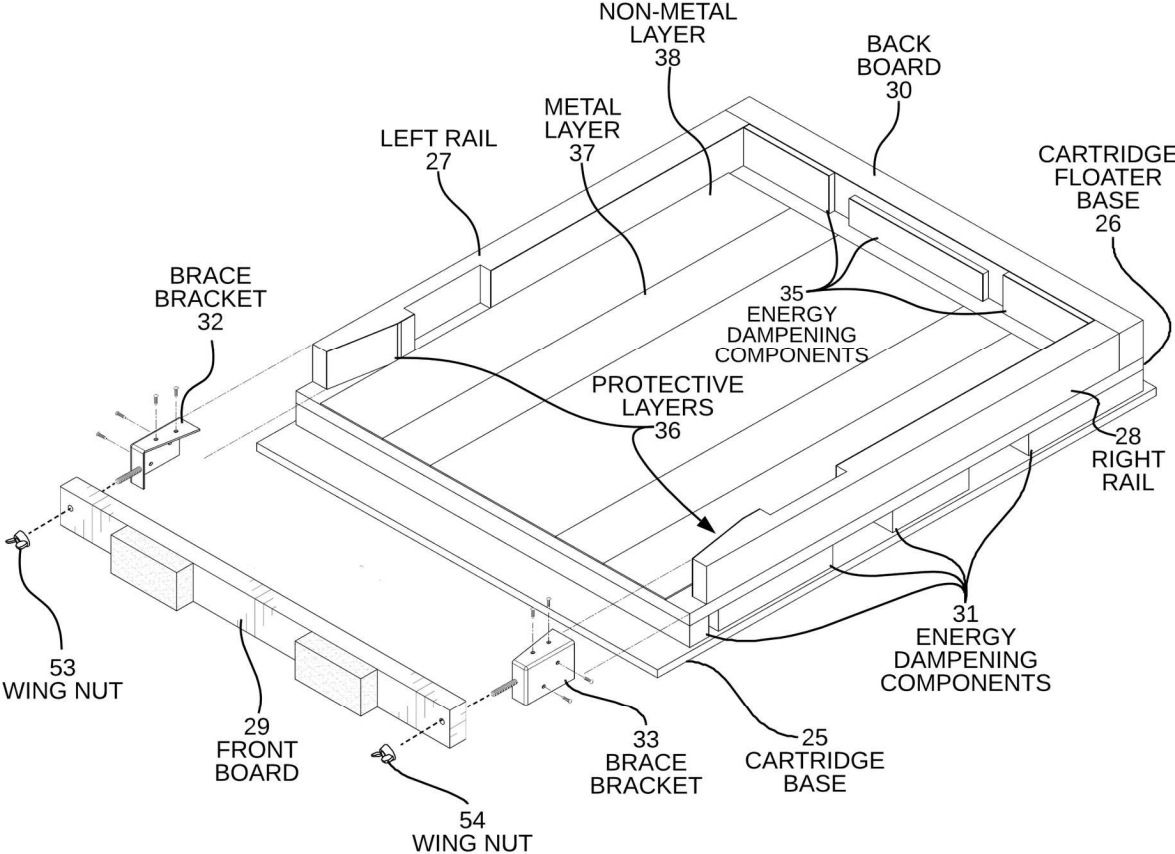

EXPLODED VIEW OF CARTRIDGE SHOWING
BRACE BRACKETS ATTACHED TO SIDE RAILS
FIG. 21

BRACE
BRACKET
32

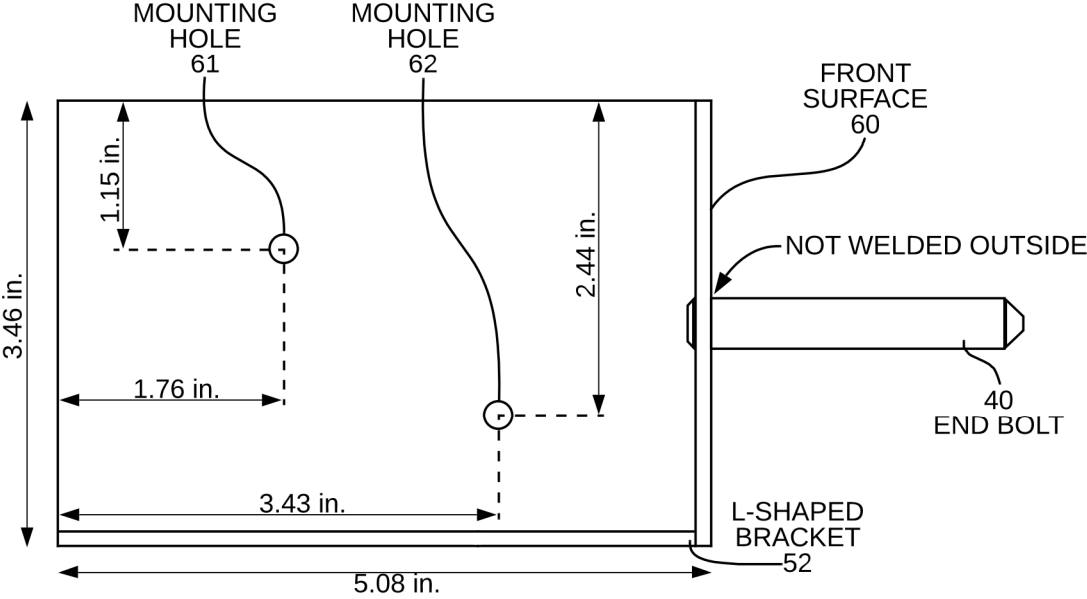

SIDE VIEW OF BRACE BRACKET
FIG. 22

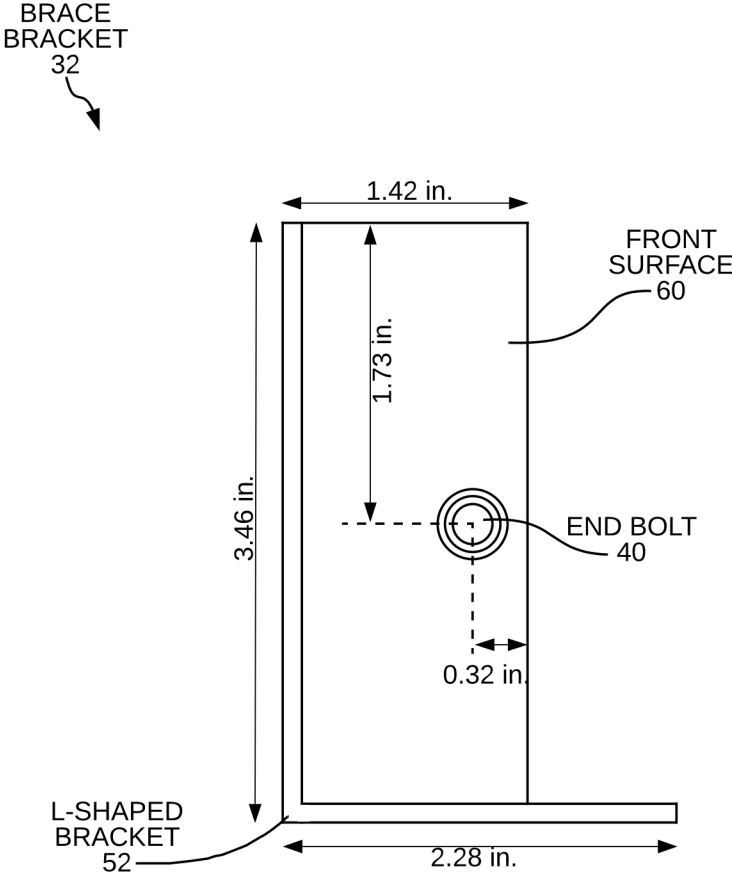

FRONT VIEW OF BRACE BRACKET
FIG. 23

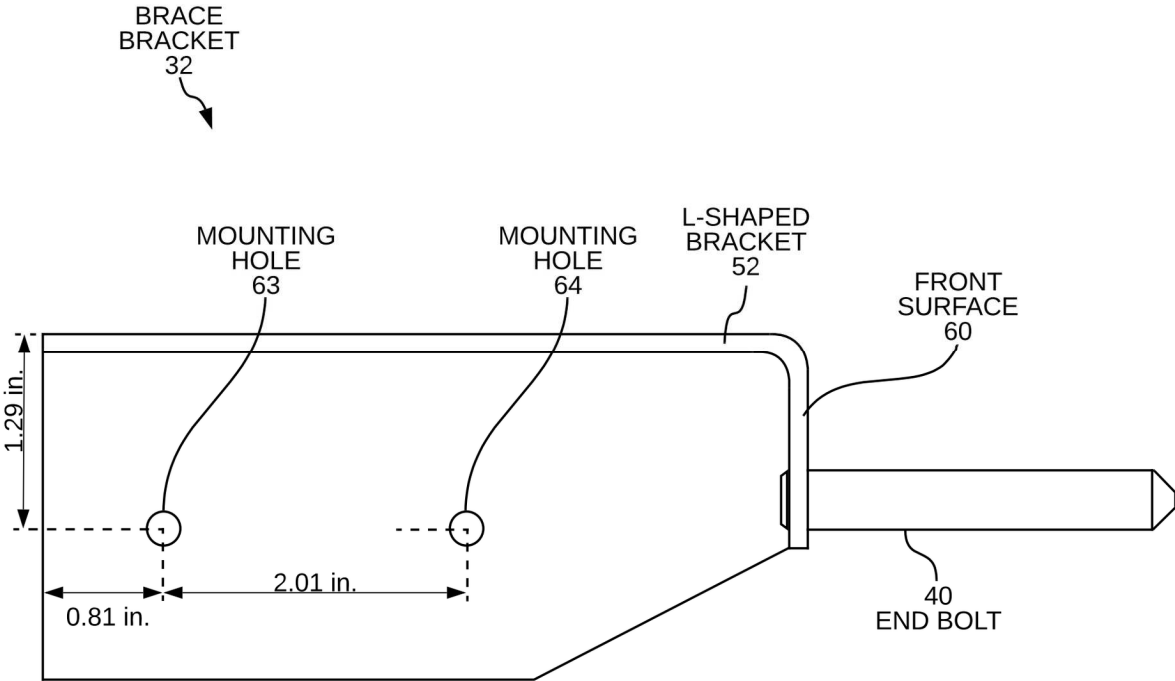

TOP-DOWN VIEW OF BRACE BRACKET
FIG. 24

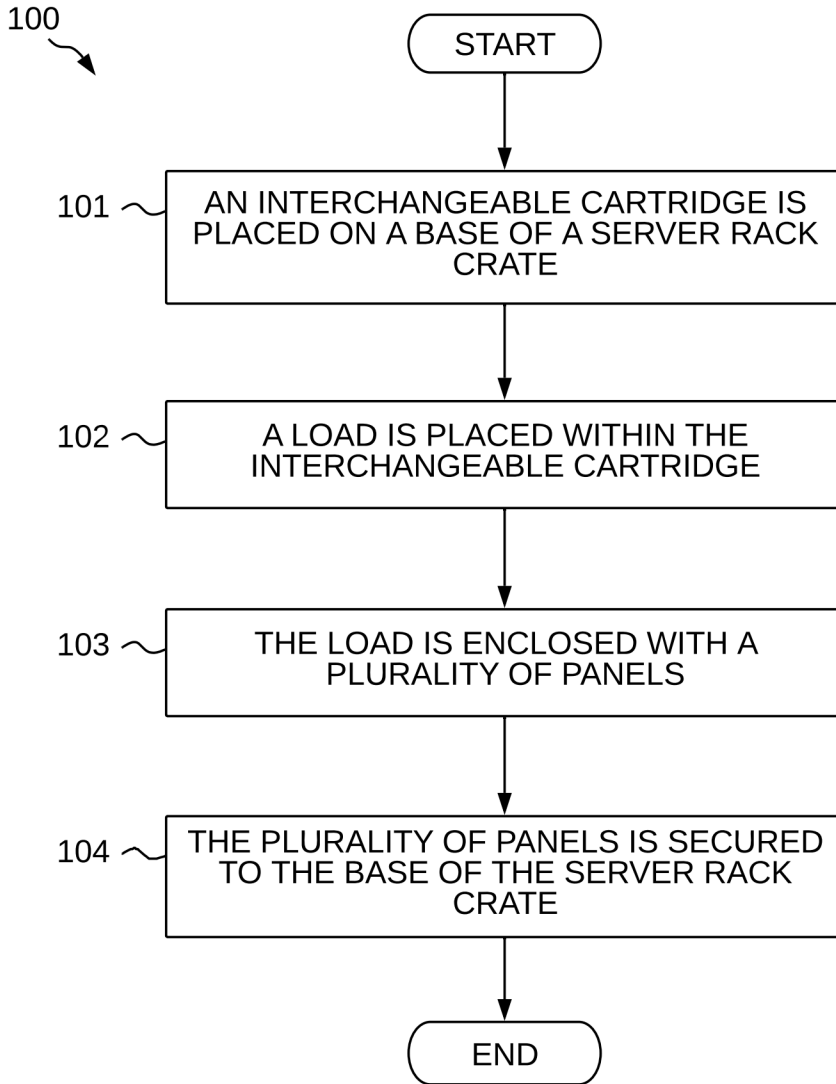

USING AN INTERCHANGEABLE CARTRIDGE TO SECURE A LOAD ON A SERVER RACK CRATE
FIG. 25

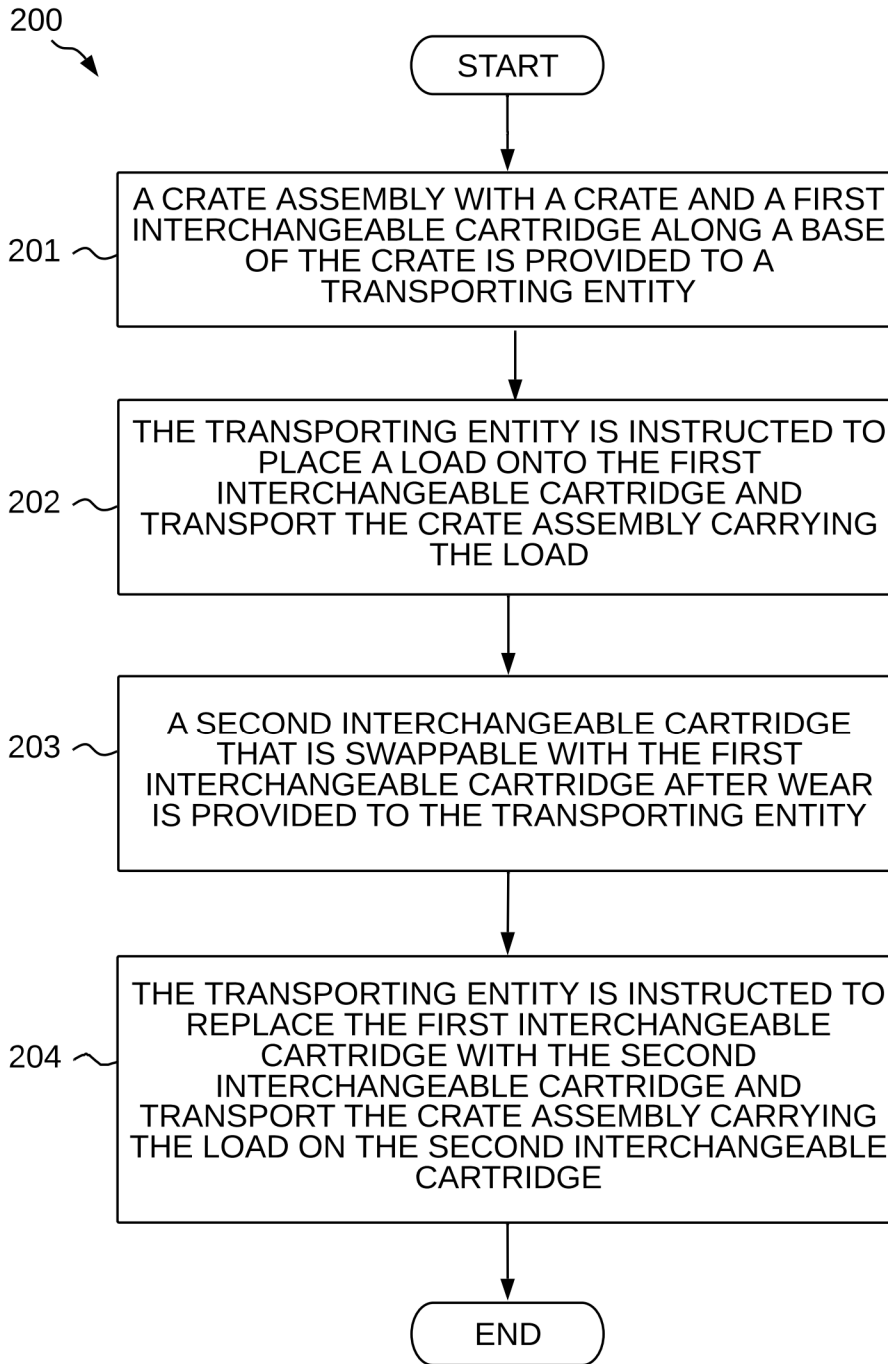

PROVIDING REPLACEMENT INTERCHANGEABLE CARTRIDGES AFTER USAGE
FIG. 26

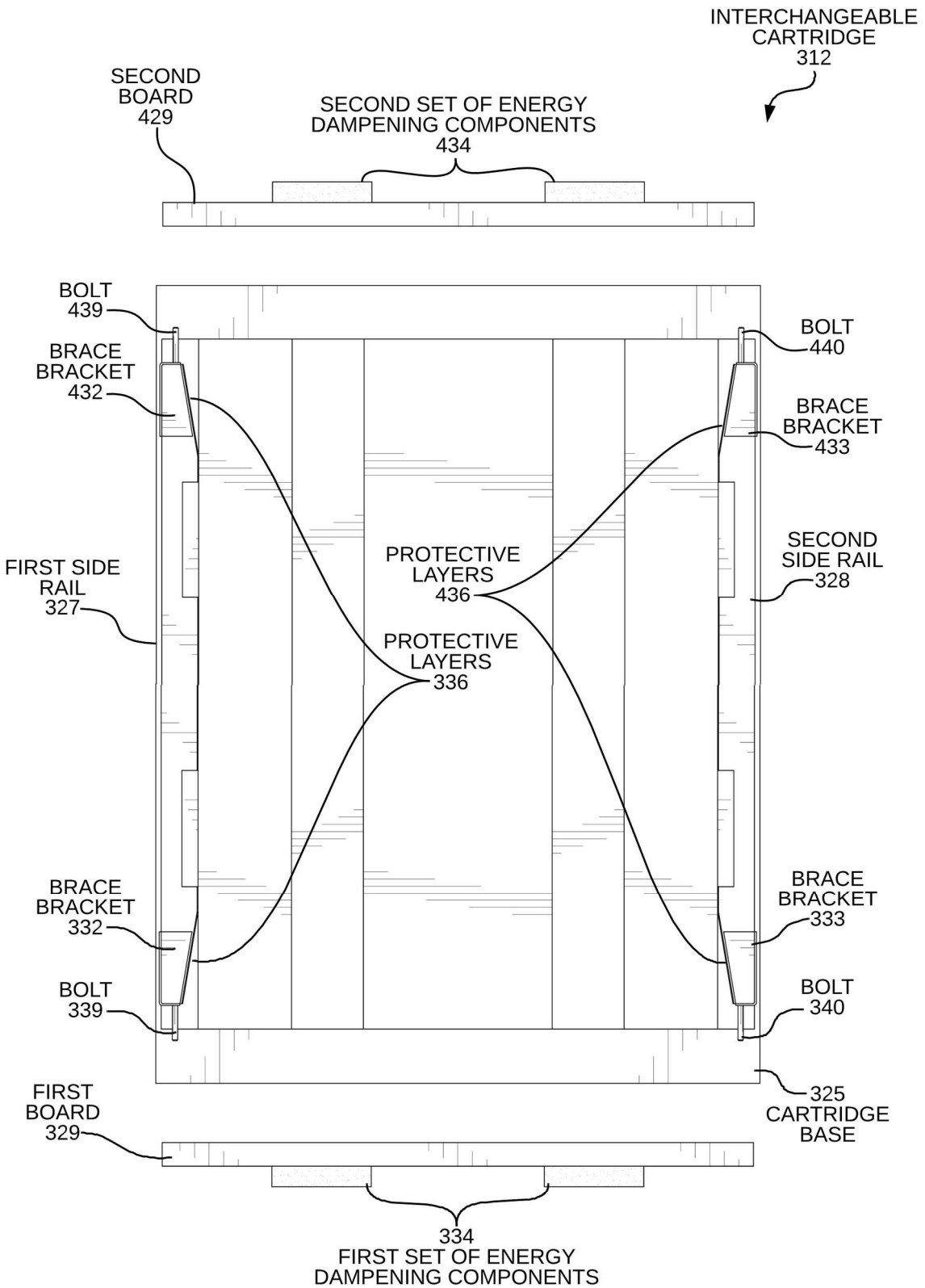

TOP VIEW OF INTERCHANGEABLE CARTRIDGE
(ANOTHER EMBODIMENT)
FIG. 27

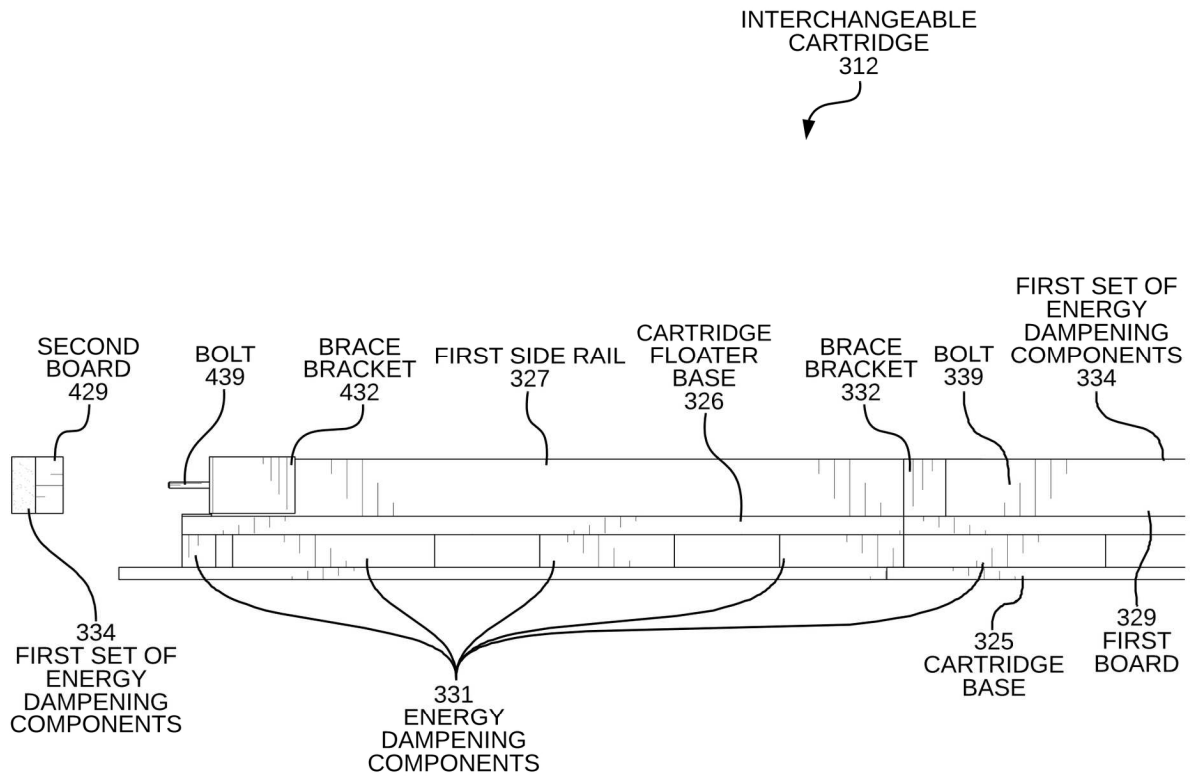

SIDE VIEW OF INTERCHANGEABLE CARTRIDGE
(ANOTHER EMBODIMENT)
FIG. 28

TOOLLESS CRATE ASSEMBLY WITH INTERCHANGEABLE CARTRIDGE

TECHNICAL FIELD

The present invention relates generally to shipping and transportation, and more specifically, to securely packaging and transporting equipment.

BACKGROUND INFORMATION

In the complex world of cloud computing and data center infrastructure, the safe and efficient transportation of high-value server racks is crucial. As technology continues to advance, the demand for robust and reliable shipping solutions for sensitive electronic equipment has grown significantly. Server racks, which house critical components of data centers and cloud computing facilities, require specialized protection during transit to prevent damage from impacts, vibrations, and environmental factors.

The logistics of transporting server racks presents unique challenges due to the size, weight, and sensitivity of the equipment. Shipping containers must be designed to withstand the rigors of various transportation methods, including truck, rail, and air freight, while maintaining a consistent level of protection throughout the journey.

SUMMARY

A crate assembly includes a crate having a base and an interchangeable cartridge supported by the base. The interchangeable cartridge is insertable and removable from the base of the crate. The interchangeable cartridge includes a cartridge base and a well. The well is formed by a cartridge floater base, cartridge side rails, a cartridge back board, and a cartridge front board. Energy damping components selected to support a desired load are disposed between the cartridge base and the cartridge floater base thereby providing cushioning to a load carried in the crate. The crate assembly is customized to support loads of various sizes and dimensions.

The interchangeable cartridge is customizable depending on application to provide a cushioning system for different configurations or weights of loads, such as server racks, storage devices, networking components, computing-related devices, or other sensitive equipment. The interchangeable cartridge is configured to have a well that matches dimensions of a load to be carried. In addition, the interchangeable cartridge includes energy damping components that provide shock absorption and vibration damping functionality. The shock and vibration absorption components are disposed between the cartridge base and the cartridge floater base.

The energy damping components are selected to dampen shock and vibration during transport and ensure the load is transported safely in the well provided by the interchangeable cartridge within the crate assembly. The shock and vibration absorption components are placed throughout the crate and interchangeable cartridge at strategic locations that maximize shock absorption characteristics while minimizing material usage that increases costs and complexity of the crate assembly.

In accordance with at least one novel aspect, the crate assembly is simple to assemble and disassemble without any specialized tools or equipment. This ease of assembly compared to conventional crate systems is partly achieved via novel brace brackets included with the crate assembly. The novel brace bracket is designed to attach to dimensional

lumber, such as 2×4, 3×4, 4×4, or other sizes, to form a well with a toolless open front (and/or back) with secure fastening. In one example, brace brackets are used to mount the front board onto the side rails of the interchangeable cartridge. Each brace bracket is affixed to a front end of a cartridge side rail. Each of the brace brackets has an end bolt that extends from a front surface of the respective brace bracket. The cartridge front board has holes that align and fit onto the end bolts of the brace brackets. The front board is toollessly attachable to the side rails via end bolts of the brace brackets and secured via wing nuts and washers.

In accordance with another novel aspect, the novel interchangeable cartridge extends the life of the crate. After the interchangeable cartridge is worn, the interchangeable cartridge is replaced and swapped with a new interchangeable cartridge instead of needing to replace the entire crate. Wear and tear is a common cause of retiring or decommissioning crates. Wear is often greatest at the base of crate assemblies which support the majority of the load. Replacing an interchangeable cartridge instead of an entire crate assembly increases the effective lifespan of other crate assembly components. In addition, replacing the interchangeable cartridge instead of the entire crate assembly decreases shipping costs and reduces environmental impact caused by waste.

Further details and embodiments and methods are described in the detailed description below. This summary does not purport to define the invention. The invention is defined by the claims.

BRIEF DESCRIPTION OF THE DRAWINGS

The accompanying drawings, where like numerals indicate like components, illustrate embodiments of the invention.

FIG. 1 is a diagram of a perspective view of a crate assembly for transporting server racks.

FIG. 2 is a diagram of a front orthogonal view of the crate assembly.

FIG. 3 is a diagram of a perspective view of an interchangeable cartridge assembly for a shipping crate.

FIG. 4 is a diagram of another perspective view of the interchangeable cartridge assembly.

FIG. 5 is a diagram of a front orthogonal view of the interchangeable cartridge assembly.

FIG. 6 is a diagram of a rear orthogonal view of an interchangeable cartridge assembly.

FIG. 7 is a diagram of a side orthogonal view of the interchangeable cartridge assembly.

FIG. 8 is a diagram of another side orthogonal view of the interchangeable cartridge assembly.

FIG. 9 is a diagram of a top view of the interchangeable cartridge assembly.

FIG. 10 is a diagram of a bottom orthogonal view of an interchangeable cartridge for a shipping crate system.

FIG. 11 is a diagram showing a perspective view of the crate assembly with the front panel installed.

FIG. 12 is a diagram of an interior view of the crate assembly showing internal panel configuration.

FIG. 13 is a diagram of a front view of the crate assembly during an installation process.

FIG. 14 is a diagram of a partial cutaway view of the crate assembly showing interior energy damping components.

FIG. 15 is a diagram of a perspective view of a server rack loading operation.

FIG. 16 is a diagram of a perspective view of the crate assembly during a server rack loading operation.

FIG. 17 is a diagram of a sectional view showing the assembly configuration of components in a shipping crate.

FIG. 18 is a diagram of a perspective view showing the installation of components in the crate assembly.

FIG. 19 is a diagram of another perspective view showing the installation of components within the crate assembly.

FIG. 20A is a diagram of a perspective view of a brace bracket.

FIG. 20B is a diagram of a perspective view of a brace bracket attached to a side rail.

FIG. 20C is a diagram of a perspective view of a brace bracket attached to dimensional lumber.

FIG. 21 is a diagram of an exploded view of a cartridge assembly showing attachment of components to side rails.

FIG. 22 is a side view of a brace bracket in accordance with one embodiment.

FIG. 23 is a front view of the brace bracket.

FIG. 24 is a top-down view of the brace bracket.

FIG. 25 is a flowchart of a method for using an interchangeable cartridge to secure a load on a server rack crate.

FIG. 26 is a flowchart of a method for providing replacement interchangeable cartridges to a transporting entity after usage thereby extending the life of a crate.

FIG. 27 is a top view diagram of another embodiment of an interchangeable cartridge.

FIG. 28 is a side view diagram of another embodiment of an interchangeable cartridge.

DETAILED DESCRIPTION

Reference will now be made in detail to some embodiments of the invention, examples of which are illustrated in the accompanying drawings.

FIG. 1 is a diagram of a crate assembly 10 in accordance with one embodiment. The crate assembly 10 includes a crate 11 and an interchangeable cartridge 12. The crate 11 comprises a base 13, a left panel 14, a right panel 15, a front panel 16, a back panel 17, and a top panel 18. The base 13 of the crate 11 is supported on skids 19. The front panel 16 includes a ramp 20 that provides a sloped surface 21 for moving a load to be transported into the crate 10. The crate 10 includes one or more energy damping components disposed throughout interior surfaces of the crate 10. In some embodiments, energy damping components refers specifically to shock absorption and vibration damping components. Reference numeral 22 identifies one of the shock absorption and vibration damping components.

FIG. 2 is a diagram showing a front orthogonal view of the crate assembly 10. The crate assembly 10 includes a crate frame 11 formed by several panels arranged to create an enclosure. The interchangeable cartridge 12 is positioned within the crate frame 11, providing protective cushioning for the contents. The interchangeable cartridge 12 is replaceable, allowing the crate assembly 10 to be reused for multiple shipments or repurposed for different loads of varying weight, dimension, or configurations.

The crate assembly 10 is designed to support multiple shipments past the point when interchangeable cartridge 12 is replaced with a new interchangeable cartridge. The amount of shipments supported by the interchangeable cartridge 12 depends on the size and weight of the load, shipment distance, and other characteristics that affect wear of the interchangeable cartridge 12. In addition, a crate can be reused or repurposed by swapping out the interchangeable cartridge 12. For example, the interchangeable cartridge 12 configured for one type of load is swappable out for

another interchangeable cartridge configured for another type of load having different weight, dimensions, or configurations.

The crate 11 is configured to carry sensitive equipment, such as servers, storage devices, networking components, and other computing related devices. In one embodiment, the crate 11 is a server rack crate that carries only servers having storage and networking components and no other types of loads. In another embodiment, the crate 11 is a computing equipment crate that carries only computing equipment and no other type of loads. In one embodiment, the load is loaded directly onto the interchangeable cartridge 12 without any intermediate structure between the load and the interchangeable cartridge 12.

The crate frame 11 comprises a base panel 13 that provides bottom support for the assembly. A left panel 14 and a right panel 15 form the side walls of the crate frame 11. In one embodiment, the left panel 14 and right panel 15 are made of wood, engineered wood, or plywood. In another embodiment, the left panel 14 and right panel 15 are made of reinforced plastic.

A front panel 16 is included in the crate assembly 10, which can be opened for access to the interior. In one embodiment, the front panel 16 is hinged. In another embodiment, the front panel 16 is completely removable.

A back panel 17 encloses the rear of the crate assembly 10. In one embodiment, the back panel 17 is fixed. In another embodiment, the back panel 17 is removable for rear access.

A top panel 18 forms the upper surface of the crate assembly 10. In one embodiment, the top panel 18 is flat. In another embodiment, the top panel 18 is slightly curved for improved water runoff.

The crate assembly 10 rests on support skids 19, which are attached to the base panel 13. In one embodiment, the support skids 19 are made of wood. In another embodiment, the support skids 19 are made of high-density plastic.

A loading ramp 20 extends from the front of the crate assembly 10, facilitating the loading and unloading of server racks. In one embodiment, the loading ramp 20 is permanently attached. In another embodiment, the loading ramp 20 is detachable for storage when not in use.

The overall structure of the crate assembly 10 creates a robust shipping container designed for protecting and transporting server rack equipment. The replaceable interchangeable cartridge 12 allows for extended use of the crate assembly 10, reducing the need for frequent replacement of the entire unit.

FIG. 3 is a diagram of a perspective view of the interchangeable cartridge 12. The interchangeable cartridge 12 includes a cartridge base 25, a cartridge floater base 26, a left rail 27, a right rail 28, a front board 29, a back board 30, energy damping components 31, and toolless brace brackets 32 and 33. The front board 29 attaches via the brace brackets 32 and 33.

The energy damping components 31 are disposed between the cartridge base 25 and cartridge floater base 26. In one embodiment, the energy damping components 31 are the only structures disposed between the cartridge base 25 and cartridge floater base 26 such that the cartridge floater base 26 rests entirely on cushioning structures and no other non-cushioning structure is between the cartridge base 25 and cartridge floater base 26. In this embodiment, the energy damping components 31 include multiple energy damping parts. In other embodiments, the energy damping components 31 are one unitary energy damping component.

The front board 29 includes one or more energy damping components 34. The back board 30 includes one or more

energy damping components **35** disposed throughout an interior surface of the back board **30**. The left rail **27** and the right rail **28** include protective layers **36** to minimize damage to loads during loading onto the interchangeable cartridge **12**. Cartridge floater base **26**, front board **29**, back board **30**, and side rails **27** and **28** together create a well **48**. A server rack or other load to be transported rests within well **48** during transit.

In one embodiment, cartridge floater base **26** includes a metal layer **37** and non-metal layer **38**. Metal layer **37** creates a smooth, durable surface for a server rack to roll or slide on without damaging the cartridge base or the crate assembly. In one embodiment, the metal layer **37** is aluminum and the non-metal layer **38** is high-impact plastic. In another embodiment, the metal layer **37** is stainless steel and the non-metal layer **38** is reinforced fiberglass, wood, or engineered wood.

Each of the brace brackets **32** and **33** includes bolts **39** and **40**, respectively. Bolt **39** extends from front surface **43** of brace bracket **32** and bolt **40** extends from front surface **44** of brace bracket **33**. The front board **29** has openings **41** and **42** that engage the bolts **39** and **40** on the brace brackets **32** and **33**. In one embodiment, a plurality of wing nuts **53** and **54** are used to secure front board **29** to bolts **39** and **40**. In another embodiment, brace brackets **32** and **33** are not present, and bolts **39** and **40** are directly mounted to side rails **27** and **28**.

FIG. **4** is a diagram showing another perspective view of the interchangeable cartridge assembly. The interchangeable cartridge assembly includes a cartridge base **25** and a cartridge floater base **26** that work together to provide structural support. In one embodiment, the cartridge base **25** is formed from wood, engineered wood, or plywood. In another embodiment, the cartridge base **25** is made of high-density polyethylene.

The assembly is bounded by a left rail **27**, a right rail **28**, and a back board **30** which form the perimeter framework. In one embodiment, the rails are made of wood or engineered wood. In another embodiment, the rails are made of aluminum. In yet another embodiment, the rails are made of steel.

The assembly incorporates multiple energy damping components **31**, **34**, and **35** positioned at strategic locations throughout the structure to maximize absorption characteristics while reducing material usage. In one embodiment, the energy damping components **31**, **34**, and **35** are made of foam. The foam is any suitable foam material that provides isotropic impact performance, ensuring consistent protection from all directions. In one example, the foam is expanded polyethylene (EPE) foam. In another example, the foam is expanded polypropylene (EPP) beaded foam. In yet another example, the foam is polyurethane (PU) foam. In still other embodiments, energy damping components are each made from different shock absorbing capable materials.

Protective layers **36** are integrated into the design, providing additional protection. In one embodiment, protective layers **36** are made of felt. The structure includes bolt connections, specifically bolt **39** and bolt **40**, which secure various components together. In one embodiment, the bolts are stainless steel. In another embodiment, the bolts are high-strength aluminum alloy.

The perspective views in FIG. **3** and FIG. **4** show how these components are arranged in a three-dimensional space, with the cartridge base **25** serving as the foundation for the assembly. The energy damping components **31**, **34**, and **35** are distributed throughout the structure to provide comprehensive protection. The rails **27** and **28**, front board **29**, and

back board **30** create a frame that contains and supports the internal components while the protective layers **36**, along with metal **37** and non-metal **38** layers provide additional protection.

FIG. **5** is a diagram showing a front orthogonal view of an interchangeable cartridge assembly. The front board **29** is positioned at the upper portion of the structure, providing support and alignment for the assembly. In one embodiment, the front board **29** is made of wood or engineered wood. In another embodiment, the front board **29** is made of aluminum. In yet another embodiment, the front board **29** is made of steel.

FIG. **6** is a diagram showing a rear orthogonal view of an interchangeable cartridge component. The view shows the back board **30** extending horizontally across the upper portion of the assembly. In one embodiment, the back board **30** is made of wood or engineered wood. In another embodiment, the back board **30** is made of steel. In yet another embodiment, the back board **30** is made of aluminum. The cartridge floater base **26** is positioned below the back board **30**. In one embodiment, the cartridge floater base **26** is formed from wood, engineering wood, or plywood. In another embodiment, the cartridge floater base **26** is made of high-density polyethylene.

FIG. **7** is a diagram showing a side orthogonal view of an interchangeable cartridge assembly. The cartridge base **25** and the cartridge floater base **26** are arranged in a horizontal configuration. In one embodiment, the cartridge base **25** is formed from wood, engineered wood, or plywood. In another embodiment, the cartridge base **25** is made of high-density polyethylene.

A right rail **28** extends along the upper portion of the assembly. In one embodiment, the right rail **28** is made of wood or engineered wood. In another embodiment, the right rail **28** is made of steel. In yet another embodiment, the right rail **28** is made of aluminum.

The assembly incorporates energy damping components **31** positioned between the cartridge base **25** and cartridge floater base **26**. In one embodiment, the energy damping components **31** are made of foam. In one example, the foam is expanded polyethylene (EPE) foam. In another example, the foam is expanded polypropylene (EPP) beaded foam. In yet another example, the foam is polyurethane (PU) foam. In still other embodiments, energy damping components **31** are each made from different shock absorbing and vibration damping capable materials.

The bolt **40** is shown protruding from the side of the assembly, providing a means for securing components together. In one embodiment, the bolt **40** is stainless steel. In another embodiment, the bolt **40** is high-strength aluminum alloy.

FIG. **8** is a diagram showing a side orthogonal view of an interchangeable cartridge assembly. The left rail **27** extends horizontally across the structure. In one embodiment, the left rail **27** is made of wood or engineered wood. In another embodiment, the left rail **27** is made of steel. In yet another embodiment, the left rail **27** is made of aluminum.

Multiple energy damping components **31** are positioned along the assembly, providing cushioning and impact protection. In one embodiment, the energy damping components **31** are made of one or more of expanded polyethylene (EPE) foam, expanded polypropylene (EPP) beaded foam, polyurethane (PU) foam, or other shock absorbing capable materials.

FIG. **9** is a diagram showing a top view of an interchangeable cartridge assembly. The cartridge base **25** forms the foundation of the structure. The perimeter of the assembly is

defined by the left rail **27**, a right rail **28**, and the back board **30**, which form the boundaries of the cartridge. A well is formed by front board **29**, left rail **27**, right rail **28**, back board **30**, and cartridge base **25**. A load, such as a server rack, to be transported rests within this well.

The assembly incorporates energy damping components **34** and **35** positioned in multiple locations—both in the upper portion of the assembly and along the bottom of the cartridge base **25**. In one embodiment, the energy damping components **34** and **35** are formed from one or more of expanded polyethylene (EPE) foam, expanded polypropylene (EPP) beaded foam, polyurethane (PU) foam, or other shock absorbing capable materials.

Protective layers **36** extend across the interior surface side rails **27** and **28**. In one embodiment, the protective layers **36** are made of felt.

In one embodiment, the top surface of cartridge floater base **26** consists of one or more metal layers **37** made of aluminum and one or more non-metal layers **38** made of wood or engineered wood. In another embodiment, metal layers **37** are made of steel, and non-metal layers **38** are made of fiberglass or high-impact plastic. The metal and non-metal layers are selected or omitted to support casters and other support features beneath the load.

The structure is secured using bolt **39** and bolt **40**, which are positioned near the front corners of the assembly. In one embodiment, the bolts are stainless steel. In another embodiment, the bolts are high-strength aluminum alloy.

FIG. **10** is a diagram showing a bottom orthogonal view of an interchangeable cartridge for a shipping crate system. The design of the interchangeable cartridge demonstrates a simple yet functional configuration that enables the cartridge to be removed and replaced within the shipping crate system. In one embodiment, the base structure is formed from wood, engineered wood, or plywood. In another embodiment, the base structure is made of high-density polyethylene.

FIG. **11** is a diagram showing a perspective view of the crate assembly **10** with the front panel **16** installed. The crate assembly **10** includes a rectangular frame structure mounted on a base **46** with support blocks. In this example, the front panel **16** is secured with a latching mechanism **45**. In one embodiment, two latching mechanisms are utilized. In some embodiments, the latching mechanisms are twist locks. In another embodiment, the latching mechanisms are cam locks.

The base of the crate incorporates a pallet-style design with multiple support blocks that facilitate handling by forklifts or pallet jacks. In one embodiment, the support blocks are made of hardwood. In another embodiment, the support blocks are made of high-density plastic.

FIG. **12** is a diagram showing an interior view of the crate assembly **10**, illustrating the internal configuration of panels with a plurality of energy damping components **47**. The crate assembly **10** comprises multiple panels that form the interior structure. The top panel **18** forms the upper boundary of the crate assembly **10**. The left panel **14** and right panel **15** are positioned on opposite sides of the crate assembly **10**, extending vertically. The back panel **17** is situated at the rear of the crate assembly **10**, connecting with the left panel **14** and right panel **15**.

In one embodiment, the panels include integrated energy damping components **47**, which appear as protruding elements from the interior surfaces. In another embodiment, the energy damping components **47** are separate inserts attached

to the panels. In another embodiment, the energy damping components **47** are a combination of integrated and separate elements.

The energy damping components **47** are arranged in a symmetrical pattern along the panels to provide protection for contents placed within the crate assembly **10**. In one embodiment, the energy damping components **47** are made of one or more of expanded polyethylene (EPE) foam, expanded polypropylene (EPP) beaded foam, polyurethane (PU) foam, or other shock absorbing capable materials.

FIG. **13** is a diagram showing a front view of the crate assembly **10** during an installation process. The crate assembly **10** comprises several panels arranged to form an enclosure, including the top panel **18**, the left panel **14**, the right panel **15**, and the back panel **17**. The figure shows the interior configuration of the crate assembly **10**, with the panels positioned to create a protective enclosure.

FIG. **14** is a diagram of a partial cutaway view of the crate assembly **10** showing interior energy damping components **47**.

FIG. **15** is a diagram showing a perspective view of a server rack loading operation. As shown in FIG. **15**, an operator **50** pushes server rack **49** along front panel **16** of the crate assembly during the loading process. In this embodiment, front panel **16** is functioning as a loading ramp to facilitate the loading of server rack **49** into crate assembly **10**.

FIG. **16** is a diagram showing a perspective view of the crate assembly **10** during a server rack loading operation.

FIG. **17** is a diagram showing an operator inserting energy damping components **47** to secure the server rack **49** within the crate assembly **10**.

FIG. **18** is a diagram showing a perspective view of the installation of components in the crate assembly **10**. The shock absorbing components **47** are secured to the interior surfaces of the crate assembly **10**, providing protection for the contents. In one embodiment, the shock absorbing components **47** are pre-cut foam inserts that are press-fit into designated spaces within the crate assembly **10**. In another embodiment, the shock absorbing components **47** are modular units that are secured using hook-and-loop fasteners, magnets, adhesives, or interlocking mechanisms for ease of installation.

FIG. **19** is another diagram showing a perspective view of the installation of components within the crate assembly **10**. As shown in FIG. **19**, the shock absorbing components **47** are positioned and secured within the interior of the crate assembly **10**. The design of the crate assembly **10** allows for proper installation and positioning of protective elements that help safeguard contents during transport. In one embodiment, the installation process includes a series of alignment markers or guides on both the crate frame and the shock absorbing components to ensure correct positioning. The assembly configuration shown in FIG. **17**, FIG. **18**, and FIG. **19** demonstrates a modular approach to installation of energy damping components that facilitates easy maintenance, replacement of worn parts, and customization for different types of server rack equipment.

FIG. **20A** is a diagram showing a perspective view of a brace bracket. The brace bracket assembly comprises a front surface **60** and an L-shaped bracket component **52**. The front surface includes a bolt **39** positioned on its face. The brace bracket **32** is formed of any suitable material capable of securely maintaining the front board fastened to the side rails during transport. In one embodiment, the brace bracket is made of steel. In another embodiment, the brace bracket is made of aluminum alloy.

The brace bracket **32** is constructed from rigid materials suitable for providing structural support and bracing. In one embodiment, the assembly is coated with a corrosion-resistant finish. In another embodiment, the assembly is left uncoated for applications where corrosion resistance is not required. In some embodiments, the L-shaped bracket component **52** is formed from a single section of sheet metal and the bolt **39** is welded to the front surface **60**.

FIG. **20B** is a diagram showing a perspective view of a brace bracket attached to a side rail. Brace bracket **32** attaches to left rail **27** using mounting holes located on L-shaped bracket component **52**. Bolt **39** allows a front board to be secured to left rail **27**. The design allows for secure attachment of front board **29** while maintaining a simple, functional configuration. In one embodiment, the brace bracket assembly is used to reinforce corners of the crate assembly. In another embodiment, the brace bracket assembly **32** is used to attach additional components to the crate assembly.

FIG. **20C** is a diagram showing a brace bracket attached to dimensional lumber. In this embodiment, the brace bracket has dimensions configured to fit onto cartridge side rails made from 2×4 dimensional lumber. 2×4 dimensional lumber has a nominal size of 2"×4", but commonly has actual dimensions of 1.5"×3.5". In other embodiments, brace brackets are configured to fit on side rails made from 3×4, 4×4, or other types of dimensional lumber. This increases ease of construction of toolless open front wells and insertable cartridges by utilizing commonly available materials.

FIG. **21** is a diagram showing an exploded view of a cartridge assembly showing how the front board **29** is toollessly attached to side rails **27** and **28**.

FIGS. **22-24** illustrate orthogonal views of a brace bracket **32** in accordance with one embodiment. The brace bracket **32** comprises an L-shaped structure with specific design features for mounting and support purposes. It is appreciated that in other embodiments, brace brackets have different dimensions configured to fit onto the cartridge side rails, dimensional lumber, or other structures.

FIG. **22** is a side view of a brace bracket in accordance with one embodiment. The brace bracket **32** has a length of 5.08 inches and a height of 3.46 inches. Brace bracket **33** includes an end bolt **40** mounted to a front surface **60**. Brace bracket **33** also includes mounting holes **61** and **62**. In this embodiment, mounting hole **61** is positioned 1.76 inches from a left edge of the brace bracket and 1.15 inches from a top edge of the brace bracket, and mounting hole **62** is positioned 3.43 inches from the left edge of the brace bracket and 2.44 inches from the top edge of the brace bracket. The drawing has a label "NOT WELDED OUTSIDE" indicating that end bolt **40** is not affixed to front surface **60** with external welds. In some embodiments, the brace bracket **33** has a height dimension over two-thirds the size of the length dimension adds to the rigidity of the brace bracket.

FIG. **23** is a front view of the brace bracket **32**. The brace bracket **33** has a height of 3.46 inches and a width of 2.28 inches, forming a 90-degree angle. The end bolt **40** is positioned 1.73 inches from the top edge of brace bracket **33**. In some embodiments, the brace bracket **33** has a width dimension over one-half the size of the height dimension to increase the rigidity of the brace bracket.

FIG. **24** is a top-down view of the brace bracket **32**. The brace bracket **32** has two mounting holes **63** and **64** are positioned 2.01 inches apart, with the first mounting hole **63** located 0.81 inches from the left edge of the brace bracket. Both mounting holes **63** and **64** are positioned 1.29 inches

from the top edge of brace bracket **33**. An end bolt **40** extends from the side at a 90-degree angle. In this embodiment, end bolt **40** is a $\frac{3}{8}$ inch bolt.

In one embodiment, the brace bracket is constructed from stainless steel to provide corrosion resistance and strength. In another embodiment, the brace bracket is made from a high-strength aluminum alloy to reduce weight while maintaining structural integrity.

The brace bracket is designed to withstand a wide range of temperatures. In one embodiment, the brace bracket is coated with a specialized thermal-resistant finish, allowing it to maintain its structural properties in temperatures ranging from -60° C. to $+100^{\circ}$ C.

In one embodiment, the brace bracket is manufactured using environmentally friendly processes and materials. The bracket is designed to be 100% recyclable at the end of its lifecycle. The brace bracket is engineered to be chemically inert. In one embodiment, the bracket is treated with a chemical-resistant coating to enhance its inertness and prevent any potential reactions with the contents of the crate or environmental factors during shipping and storage.

In another embodiment, the dimensions of the brace bracket are scaled up or down to accommodate different sizes of crate assemblies. In one embodiment, the mounting holes in the brace bracket are threaded to accept screws directly, eliminating the need for separate nuts and simplifying the assembly process. In another embodiment, the mounting holes are oversized and include integrated bushings to allow for minor adjustments during installation.

As indicated in FIG. **22** ("NOT WELDED OUTSIDE" label), the end bolt **40** is not welded to the front surface **60**. Avoiding welding on the front surface **60** ensures that after installation of the front board, the front surface **60** is flush with and forms a secure contact with the front board. In some embodiments, portions of the brace bracket are reinforced using a cold-forming process instead of welding. In another embodiment, portions of the brace bracket are strengthened using a high-strength adhesive bonding process.

The end bolt **40** shown in the top-down view (FIG. **24**) is a critical component of the bracket's mounting system. In one embodiment, this bolt is a $\frac{3}{8}$ inch bolt. In another embodiment, this bolt is replaced with a metric M10 bolt for compatibility with international standards. In yet another embodiment, the bolt is integrated directly into the bracket as a stud, reducing the number of separate components in the assembly.

FIG. **25** is a diagram showing a flowchart of a method **100** for using an interchangeable cartridge to secure a load on a server rack crate.

In a first step (step **101**), an interchangeable cartridge is placed on a base of a server rack crate.

In a second step (step **102**), a load is placed within the interchangeable cartridge.

In a third step (step **103**), the load is enclosed with a plurality of panels.

In a fourth step (step **104**), the plurality of panels is secured to the base of the server rack crate.

FIG. **26** is a diagram showing a flowchart of a method **200** for providing replacement interchangeable cartridges to a transporting entity after usage thereby extending life of the crate assembly.

In a first step (step **201**), a crate assembly with a crate and an interchangeable cartridge along a base of the crate is provided to a transporting entity.

11

In a second step (step **202**), the transporting entity is instructed to place a load onto the cartridge and transport the crate assembly carrying the load.

In a third step (step **203**), a second interchangeable cartridge that is swappable with the first interchangeable cartridge after wear is provided to the transporting entity.

In a fourth step (step **204**), the transporting entity is instructed to replace the first interchangeable cartridge with the second interchangeable cartridge and transport the crate assembly carrying the load on the second interchangeable cartridge.

The novel method **200** extends the life of the crate. After the interchangeable cartridge is worn, the interchangeable cartridge is replaced and swapped with a new interchangeable cartridge instead of needing to replace the entire crate. Replacing an interchangeable cartridge instead of an entire crate assembly increases the effective lifespan of the crate. In addition, replacing the interchangeable cartridge instead of the entire crate decreases shipping costs and reduces environmental impact.

FIG. **27** is a diagram showing a top view of another embodiment of an interchangeable cartridge assembly **312**. The cartridge base **325** forms the foundation of the structure. Sidewalls of the assembly are defined by a first rail **327** and a second rail **328**. A well is formed by a first board **329**, first rail **327**, second rail **328**, a second board **429**, and cartridge base **325**. A server rack to be transported rests within this well.

The assembly **312** incorporates a first set of energy damping components **334** and a second set of energy damping components **434** positioned in multiple locations. Energy damping components **334** and **434** are positioned on the exterior surfaces of first and second boards **329** and **429**. In other embodiments, energy damping components **334** and **434** are positioned on the interior surfaces of first and second boards **329** and **429**. In one embodiment, the energy damping components **334** and **335** are formed from one or more of expanded polyethylene (EPE) foam, expanded polypropylene (EPP) beaded foam, polyurethane (PU) foam, or other shock absorbing and vibration damping capable materials.

Protective layers **336** and **436** extend across the interior surface of side rails **327** and **328**. In one embodiment, the protective layers **336** and **436** are made of felt. In some embodiments, protective layers **336** and **436** extend across the entire interior surface of side rails **327** and **328** respectively. In other embodiments, protective layers **336** and **436** are each split into two sections where the middle portions of side rails **327** and **328** are not covered by protective layers **336** and **436**.

The structure is secured using bolts **339**, **340**, **439**, and **440**, which are positioned near the corners of the assembly. In one embodiment, the bolts are stainless steel. In another embodiment, the bolts are high-strength aluminum alloy.

FIG. **28** is a diagram showing a side view of another embodiment of an interchangeable cartridge assembly **312**. The cartridge floater base **325** is disposed above energy damping components **331**, which are disposed above cartridge base **325**. In one embodiment, the cartridge base **325** is formed from wood, engineered wood, or plywood. In another embodiment, cartridge base **325** is made of high-density polyethylene.

A first rail **327** extends along the upper portion of the assembly. In one embodiment, the first rail **327** is made of wood or engineered wood. In another embodiment, the first rail **327** is made of steel or aluminum.

12

Energy damping components **331** are positioned between cartridge base **325** and cartridge floater base **326**. In some embodiments, the energy damping components **331** are made of foam. In one embodiment, the foam is expanded polyethylene (EPE) foam. In another embodiment, the foam is expanded polypropylene (EPP) beaded foam. In yet another embodiment, the foam is polyurethane (PU) foam. In still other embodiments, energy damping components **331** are each made from different shock absorbing and vibration damping materials.

A pair of brace brackets **332** and **432** are shown at each end of first rail **327**. A pair of bolts **339** and **439** are each attached to brace brackets **332** and **432**. First board **329** is attached to the interchangeable cartridge via bolts **339** and **340**. Second board **429** is attached to the interchangeable cartridge via bolts **439** and **440**.

Although certain specific embodiments are described above for instructional purposes, the teachings of this patent document have general applicability and are not limited to the specific embodiments described above. Accordingly, various modifications, adaptations, and combinations of various features of the described embodiments can be practiced without departing from the scope of the invention as set forth in the claims.

What is claimed is:

1. A crate assembly comprising:

a crate having a base; and

an interchangeable cartridge, wherein the interchangeable cartridge is supported by the base of the crate, wherein the interchangeable cartridge is insertable and removable from the base of the crate, and wherein the interchangeable cartridge comprises:

a cartridge base;

a cartridge floater base;

a plurality of cartridge side rails;

a cartridge back board;

a cartridge front board, wherein the cartridge floater base, cartridge side rails, cartridge back board, and cartridge front board form a well; and

an energy damping component, wherein the energy damping component is disposed between the cartridge base and the cartridge floater base.

2. The crate assembly of claim **1**, wherein the energy damping component comprises one or more layers of foam, and wherein the energy damping component is selected to support a load within the crate.

3. The crate assembly of claim **1**, further comprising:

a plurality of brace brackets, wherein each brace bracket is affixed to a front end of a cartridge side rail.

4. The crate assembly of claim **3**, wherein each of the brace brackets has an end bolt that extends from a front surface of the brace bracket.

5. The crate assembly of claim **4**, wherein the cartridge front board is toollessly attachable to the cartridge side rails by sliding openings on the cartridge front board onto end bolts of the brace brackets and securing fasteners over the end bolts such that the cartridge front board is between the fasteners and the cartridge side rails.

6. The crate assembly of claim **1**, further comprising: a plurality of end bolts, wherein each end bolt is affixed to a front end of a cartridge side rail.

7. The crate assembly of claim **1**, further comprising: an additional energy damping component, wherein the additional energy damping component is disposed on an exterior surface of the cartridge front board and is configured to contact a front panel of the crate.

13

- 8. The crate assembly of claim 1, further comprising:
an additional energy damping component, wherein the
additional energy damping component is disposed on
an interior surface of the cartridge back board and is
configured to contact a load supported by the inter-
changeable cartridge. 5
- 9. The crate assembly of claim 1, wherein the interchange-
able cartridge is configurable to support loads of different
weights and dimensions.
- 10. The crate assembly of claim 1, wherein the inter-
changeable cartridge is swappable with a new interchange-
able cartridge such that the crate is reusable. 10
- 11. The crate assembly of claim 1, further comprising:
a plurality of brace brackets, wherein each brace bracket 15
is affixed to a front end or a back end of a cartridge side
rail, wherein each of the brace brackets has an end bolt
that extends from a front end of the brace bracket, and
wherein the cartridge front board or the cartridge back
board is toollessly attachable to the cartridge side rails
via end bolts of the brace brackets. 20
- 12. A method of assembling a crate comprising:
placing an interchangeable cartridge on a base of a server
rack crate, wherein the interchangeable cartridge com-
prises:

14

- a cartridge base;
- a cartridge floater base;
- a plurality of cartridge side rails;
- a cartridge back board;
- a cartridge front board, wherein the cartridge floater
base, cartridge side rails, cartridge back board, and
cartridge front board form a well; and
an energy damping component, wherein the energy
damping component is disposed between the car-
tridge base and the cartridge floater base; 5
placing a load onto the interchangeable cartridge;
enclosing the load with a plurality of panels; and
securing the plurality of panels to the base of the server
rack crate.
- 13. The method of claim 12, further comprising:
securing a front panel to a front of the crate.
- 14. The method of claim 12, wherein the interchangeable
cartridge provides shock protection and vibration damping
to a server rack placed on the interchangeable cartridge.
- 15. The method of claim 12, wherein the interchangeable
cartridge is configurable to support server racks of different
weights and dimensions. 10
- 16. The method of claim 12, wherein the load is a server
rack that is placed within a well of the interchangeable
cartridge.

* * * * *